

Vigilon

*A*dvanced
*F*ire *D*etection and
*A*larm *S*ystem

Operating Manual
VIG-MAN-OPS Issue 1
January 1999



G E N T

Preface

This first issue covers instructions for operating the equipment in emergency and non emergency conditions

Associated Documents

13563-011	GENT Supervisor Operating Manual
VIG-MAN-INS	Installation manual for Vigilon

The information contained herein is the property of GENT LIMITED and is supplied without liability for errors or omissions. No part of the manual may be reproduced in any form soever without prior consent of the company. Due to the on going development of GENT System Vigilon the information contained in the manual is subject to change without notice.

Contents

	Page Number
Vigilon Equipment	4
Visible and Audible Indications	4
User Responsibility	5
Daily	5
Weekly	5
Quarterly	6
Battery Replacement	6
Manual Call Point	6
Basic Maintenance	7
Replacing a broken glass	7
Replacing printer paper	8
Controls and Indicators	9
First level controls	9
Description of main controls and indicators	10
Normal condition	11
Emergency conditions	12
How to manually raise an alarm of fire	12
Automatic detection	12
Fault conditions	14
Disablement conditions	16
Instructions for MENU ON/OFF	18
Testing the display	18
Setting the system clock	19
Using the printer	20
Enabling or disabling parts of the system	21
Viewing Active events	28
Viewing Historic events	29
Saving changes to the memory card	30
Changing the UserCode Password	31
Labelling	32
Editing Label Information	32
Viewing labels	36
Removing and Changing devices	40
System modifications	40
Configuring a SAFE Address	43
Vigilon system parts	46
Index	53
Notes	57

Vigilon Equipment

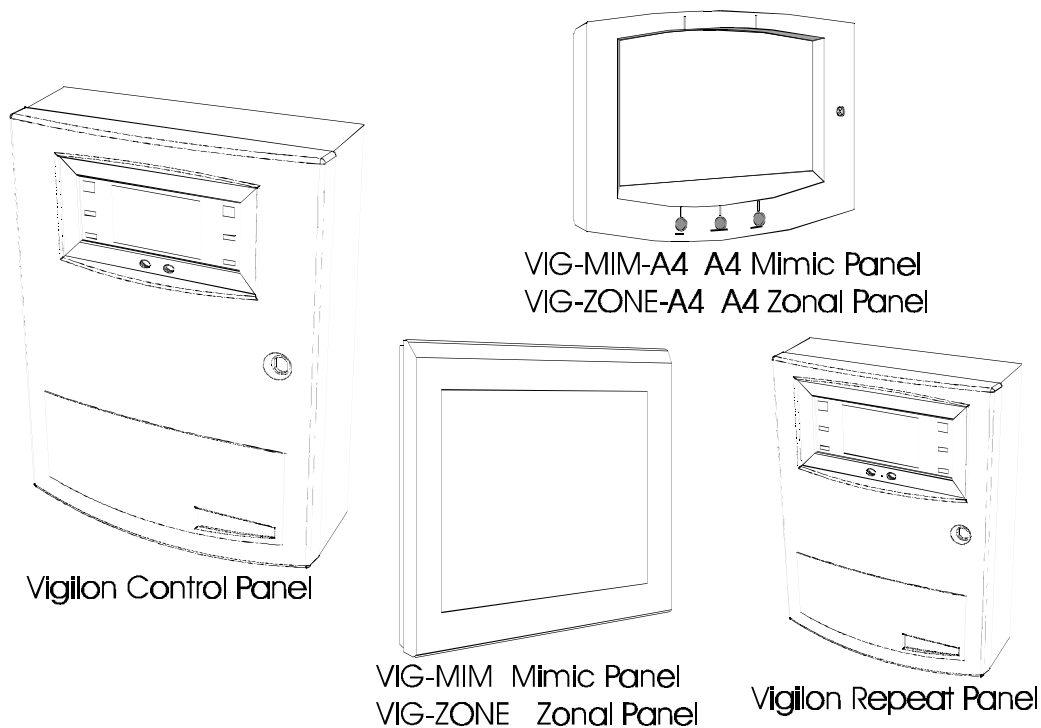

Figure 1 Control and Indicating equipment
cdn305

Visual and audible Indications

Control, Repeat and Terminal node

The control panel, repeat panel and terminal node indicate events by means of:

- messages on a display/ screen (Liquid Crystal Display - LCD)
- accompanied with illumination of appropriate colour coded light
- and an audible sound from within the panel given by a two tone buzzer.

Mimic & Zonal panels

These panels provide indications by means of red fire indicators located behind a site map or zone designation. An internal buzzer provides an audible indication of a fire and local fault.

The A4 Mimic panel also has common lights that operate with fire, local power supply status and local faults.

NOTE: The A4 mimic panel has an internal buzzer disabling facility which is configured during commissioning of the system. If the buzzer is disabled then it will not sound in an event condition.

User Responsibility

It is recommended that the persons responsible for the fire alarm system should become familiar with:

- How to operate the controls.
- Interpreting the indications given.

NOTE: If your system is designed to meet the requirements of BS 5839:Part 4:1988, then the use of **[Disable] [IO Line]** option under the **[Control]** menu and **[Set Clock]** option under the **[Setup]** menu using the 'Customer Password' is not recommended.

Daily

BS 5839:Part 1:1988, states that the system should be inspected daily to ensure

- That a normal indication is given at the control and indicating equipment.
- That any previously indicated fault and warning condition has received appropriate attention.
- All the system events are entered into the Log Book for future reference.
- That the use of the area(s) inspected has not changed since the system was designed.
- That no unsafe practices that could lead to fire are being undertaken.

Weekly

- A different Fire Sensor or Manual Call Point of the system should be tested to ensure the system is capable of operating under alarm condition.
- The operation of the alarm sounders should be checked to also remind those occupying the premises that there is a fire alarm system with a particular sound.

NOTE: The test should be performed at a regular time to avoid confusion between a test and a genuine fire alarm.

Quarterly

- At quarterly intervals the system should be inspected and any work necessary should be performed by a trained maintenance engineer.

NOTE: For help with Maintenance and Service, please contact the your servicing organisation.

Battery Replacement

NOTE: Any servicing work on the Vigilon system must be carried out by a suitably trained person such as a service engineer.

Panel Battery

- It is recommended that these batteries are replaced at 4 Yearly interval from the date the Vigilon System is first commissioned.

Memory Card Battery

- It is recommended that the Memory Card is replaced at 10 Yearly interval from the date the Vigilon system is commissioned.

CAUTION: It is recommended that the Memory card replacement is carried out by a suitably trained engineer such as a Service Engineer, due to the possibility of loss of System labelling and configuration information if the card is incorrectly replaced.

Manual Call Point

Testing a Manual Call Point

Push the test key through the hole in the underside of the call point to engage the test cam mechanism and push to operate the cam mechanism.

At this point the test key is retained in the call point and pulling it out will reset the glass.

NOTE: The appropriate sounders in the system will be activated by this test. To **silence alarms** and **reset** the system, see **Emergency controls** part of this manual.

Basic Maintenance

Replacing a broken Glass

WARNING: Take appropriate precautions when clearing broken glass to prevent injury.

NOTE: A weather resistant version of manual call points will have two gaskets, a Cover/glass gasket and a Spacer/cover gasket, which must be installed in their respective position.

These procedures assume the cover on the manual call point is open and any broken glass has been cleared.

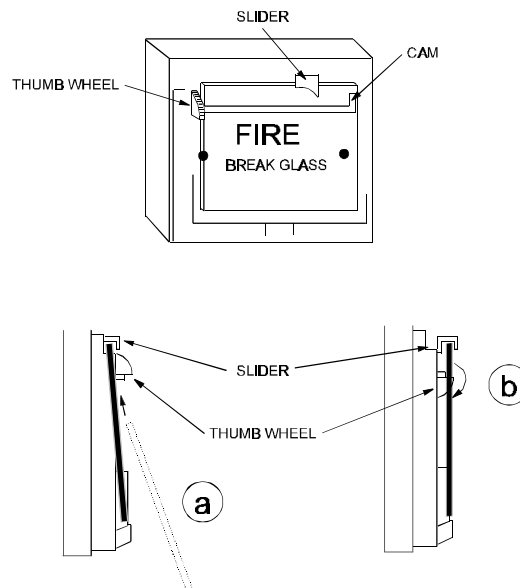

Figure 2 Replacing a broken MCP glass
cdn461

- a) Feed the glass upward to push the cams down and fit under slider, locate bottom of glass into recess.
- b) Hold the bottom of glass in position and rotate the thumbwheel quadrant to raise the top of the glass.
- c) Fit the call point cover by hooking it into the top of the unit and making sure that the glass is properly seated (held down) tighten the cover fixing screw.
- d) Test that the manual call point functions correctly.

Replating Printer Paper

The printer paper roll is located on the inside of the inner door. A vertical line on the paper indicates end of paper. A new paper roll code number VIG-PAPER must be fitted.

- a) Open the main door using the key supplied and inner door using the allen key supplied.
- b) Remove the old paper roll from inside of door assembly.
- c) Fit a new paper roll
- d) Insert paper into the printer mechanism.

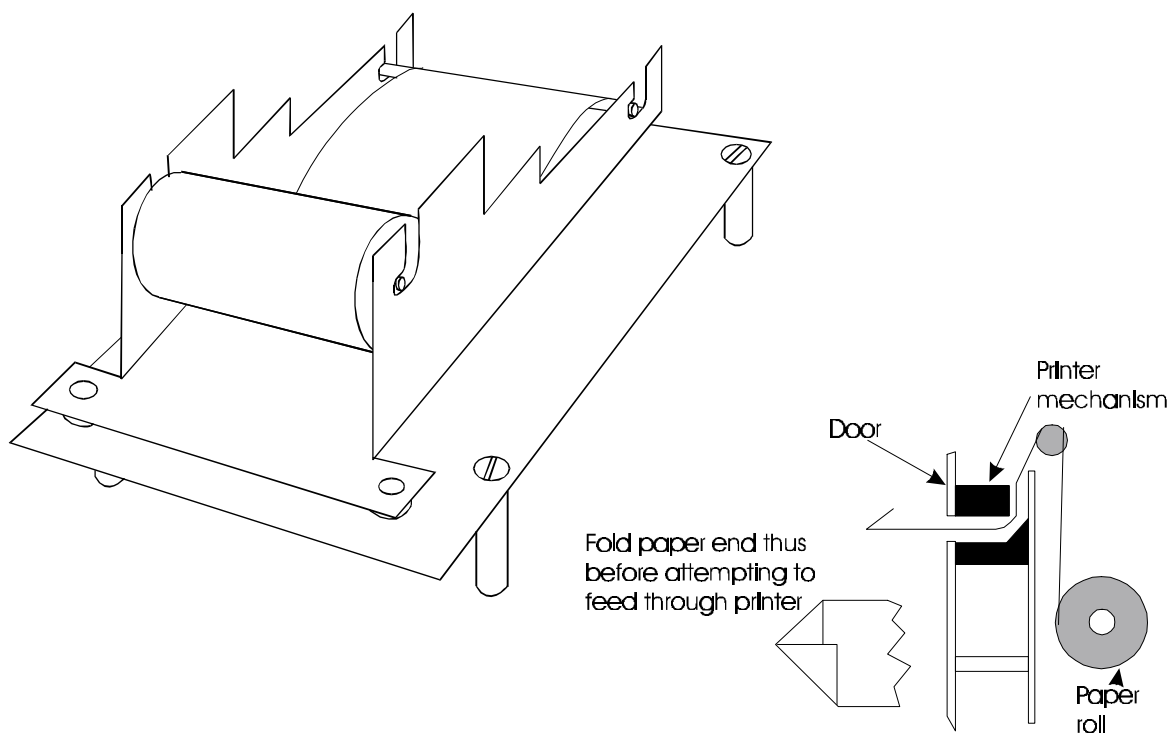

Figure 3 Loading the printer paper

cdn304

- e) Turn the wheel on the inner door downwards to feed the printer paper.
- g) Close the control panel door(s).
- f) Carry out a printer paper test, see panel controls section of this manual.

Controls and Indicators

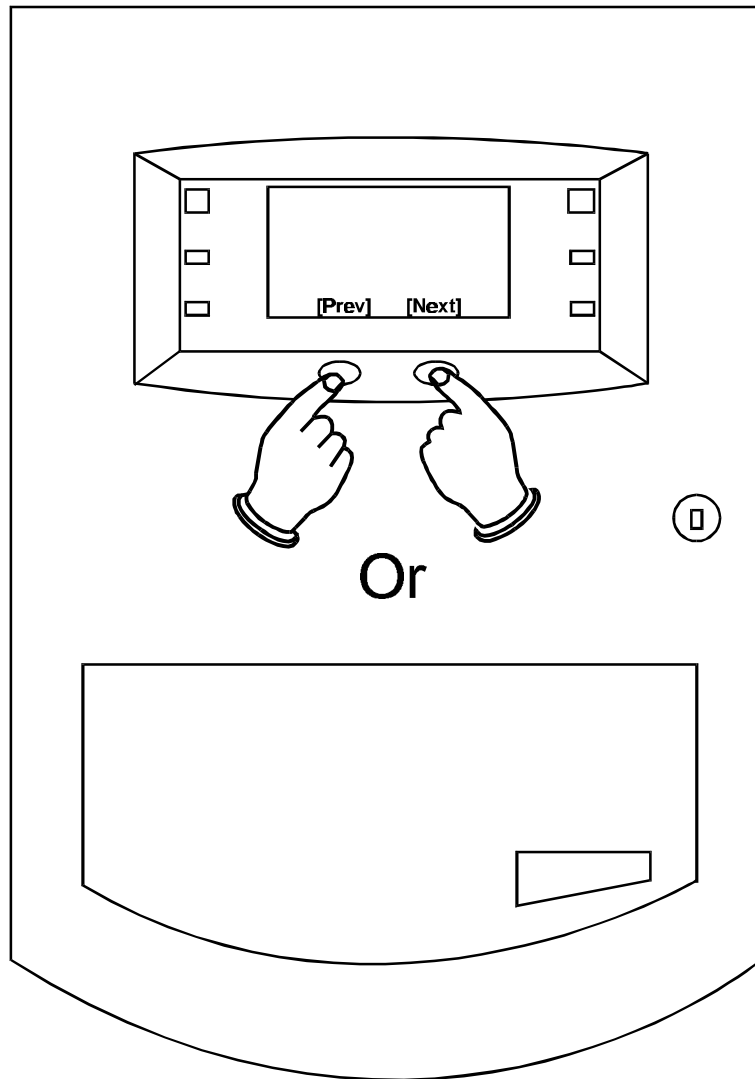

Figure 4 First level access controls.
cdn360

First level controls

The FIRE events displayed can be scrolled through by utilising the first level controls located as shown on the panel front door.

Description of main controls and indicators

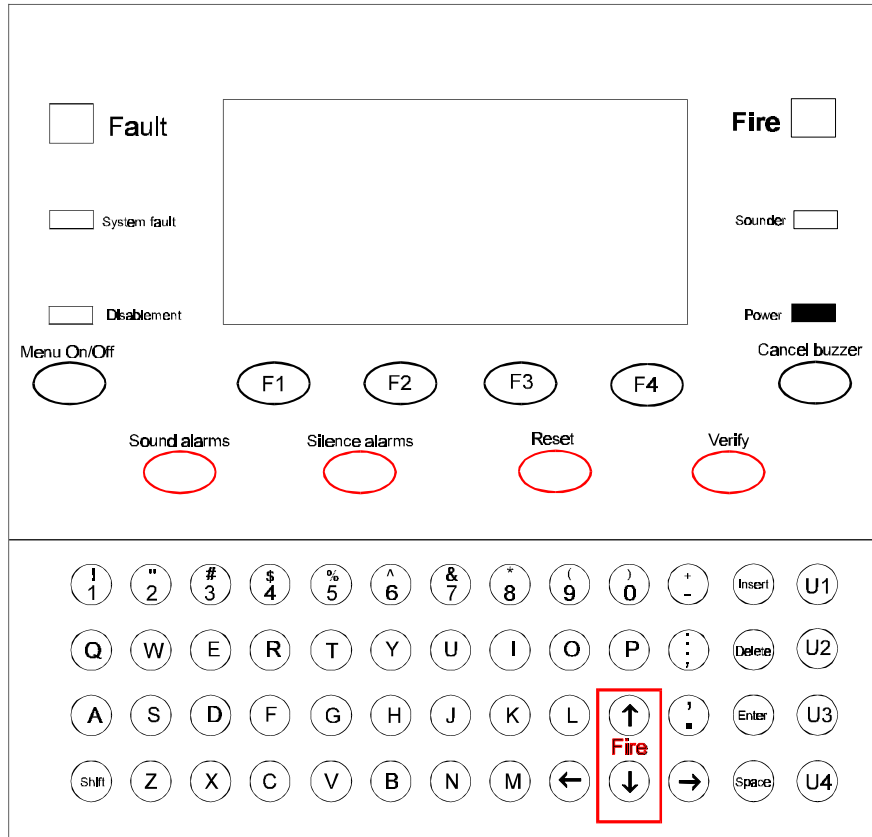

Figure 5 Controls and Indicators
cdn361

- Indicators**
- Power - When illuminated indicates that the panel is powered up.
 - Fire - When illuminated indicates that a FIRE has been detected by the fire detection system.
 - Fault - When illuminated indicates that a failure has occurred within the system which requires rectification.
 - System Fault - When illuminated indicates that there has been a fault occurring with a system processor.
 - Disablement - When illuminated indicates that a part of the system has been disabled.
 - Sounder - When illuminated (always with either the FAULT lamp or the DISABLEMENT lamp) indicates that there is a sounder fault or disablement.
- Controls**
- Menu On/Off - Pressing Menu On/Off enables/disables the on screen menu facility which gives access to the system menus.
 - F1-F4 - The function buttons are used to select functions and sub-functions of the system menus which appear on the display. Each option in the menus, corresponds to one of the function buttons and pressing a button will select the option which appears above it on the display.

- Cancel Buzzer** - The Cancel Buzzer button will when pressed stop the internal panel buzzer from sounding.
- Sound alarms** - Pressing the Sound Alarms will sound all of the systems alarms. Should only be pressed in an emergency or at other agreed times, ie System tests, Practice Evacuations and so forth.
- Silence alarms** - Pressing the Silence Alarms button will silence the system alarms. Should only be pressed when the emergency is over.
- Reset** - Pressing the Reset button will clear any fires and return the panel to its normal state. If a fire condition re-occurs immediately after reset then the indicated device should be investigated. If the panel indicates 'Call Point not Reset' then the indicated call point glass should be replaced.
- Verify** - If the Verify facility has been set up, then pressing Verify on detection of a fire condition, increases the time delay before the sounders are activated, thus allowing the 'fire' to be investigated.
- U1-U4** - These buttons if set up at the commissioning stage, will initiate one of four user defined functions. The function of these buttons should be written on the label on the inside of the outer door.
- Fire ↑↓** - The two fire scroll buttons on the keyboard, operate in exactly the same way as the two first level access fire scroll buttons on the front door. They are activated when the door is open.
- Qwerty keypad** - Allows the entering of alphanumeric information into the panel.

Normal Condition

The following is the normal operating condition of the panel:

- Fire, Fault System Fault, Sounder and Disablement indicators all unlit
- Power indicator lit

Figure 6 Normal indication on panel

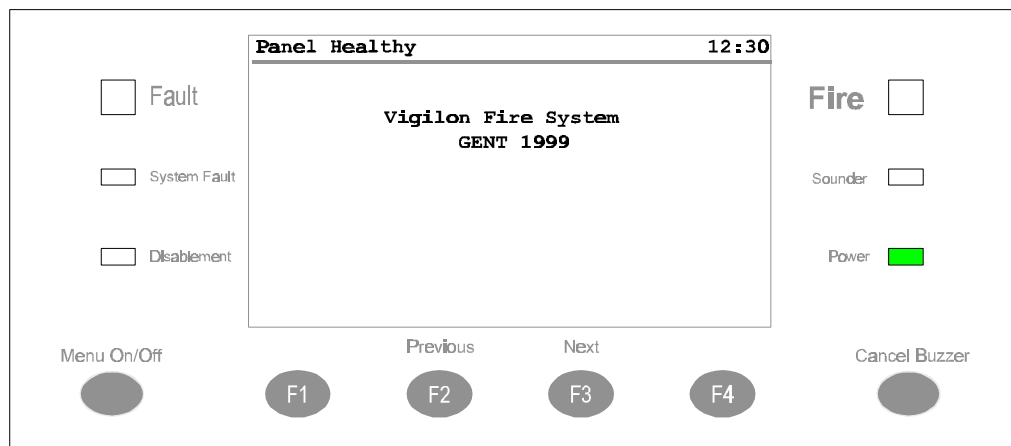

cdn342

Emergency Conditions

How to manually raise an alarm of FIRE

- Go to nearest manual call point that is located away from the fire hazard
- Press hard with thumb onto the centre of the Glass until it breaks.

Automatic detection

A fire event detected by the sensors or fire inputs from interfaces is automatically actioned by the Control Panel.

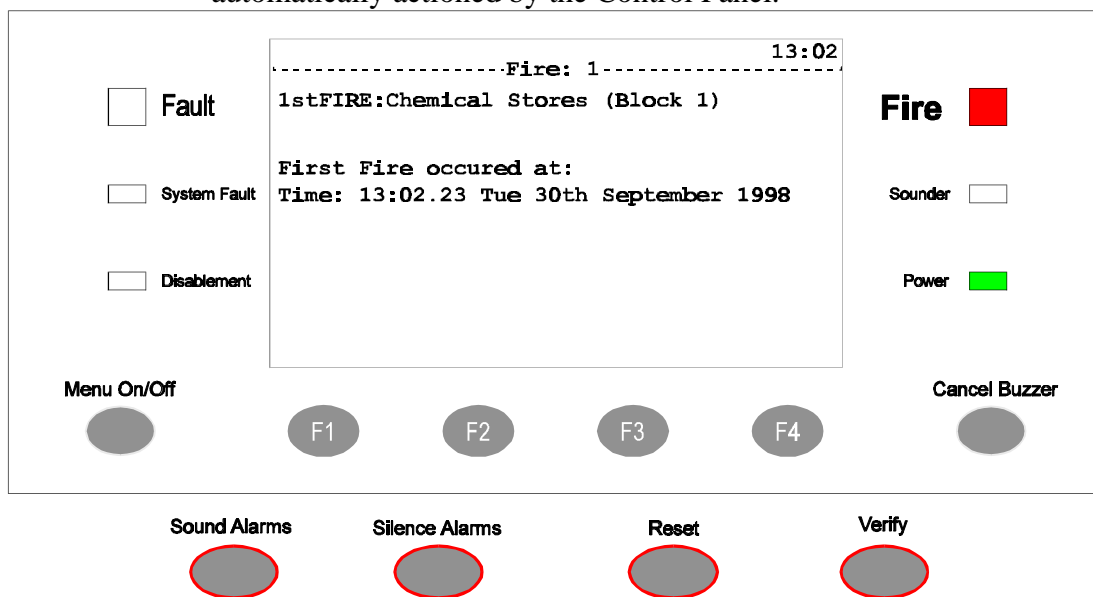

Figure 7 Fire indication at control panel
cdn348

To cancel panel buzzer:

- Press the Cancel buzzer button

To silence alarms (Emergency over):

- Press the Silence Alarms Button.
- Display reads 'Alarms silenced'

To reset system:

- Clear any residual smoke or heat from detectors and replace glass in any manual call points where the glass was broken.
- Press the Reset button
- Display reads 'System being Reset - please wait...'
- Record event in log book.

Multiple fires

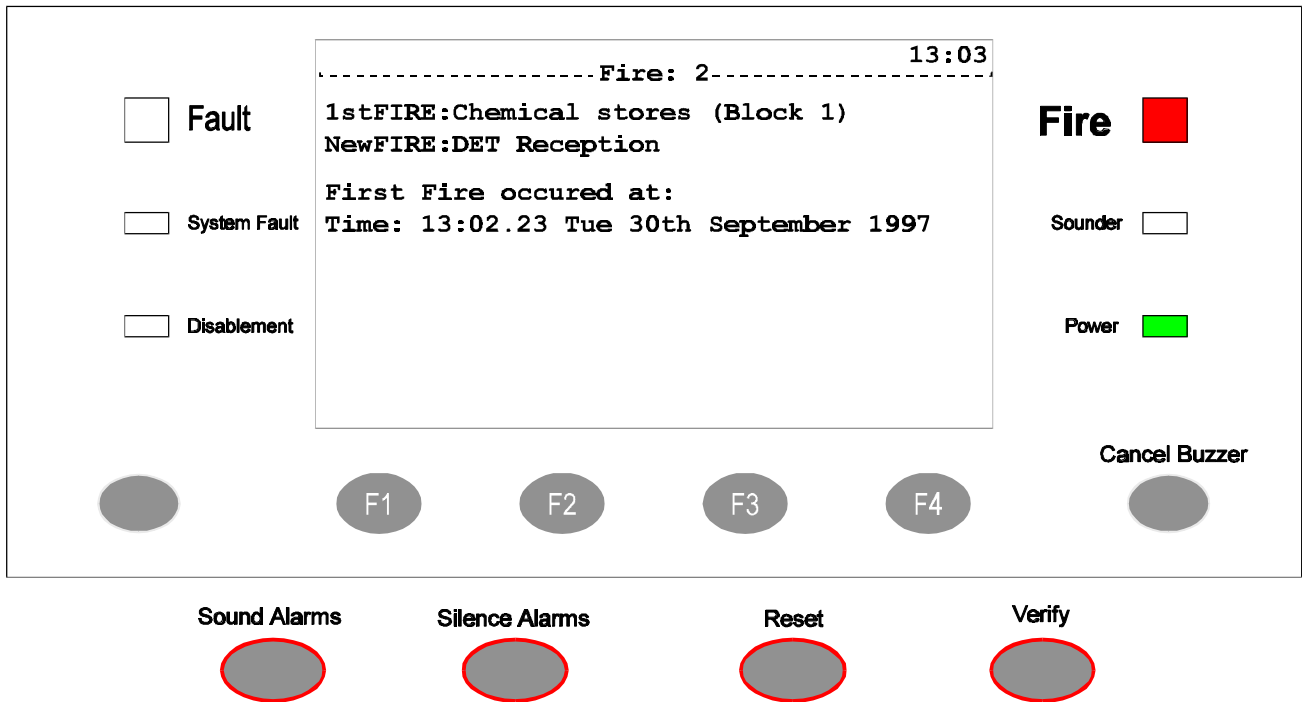

Figure 8 Multiple fires indication
cdn349

- 1st Fire always appears at top of display
- All subsequent fires appear beneath 1st Fire
- Use the Fire $\uparrow\downarrow$ keys to scroll through the fires, or if the outer door is closed use the [Prev] or [Next] buttons.

Verify (if required by site procedures)

- Upon receipt of a fire condition via the panel (message and buzzer) press the Verify button.
 - Delayed sounders are further delayed by a pre-configured delay.
- Investigate the cause of the fire alarm.
- The delayed sounders will operate after the delay period has timed out.

Fault conditions

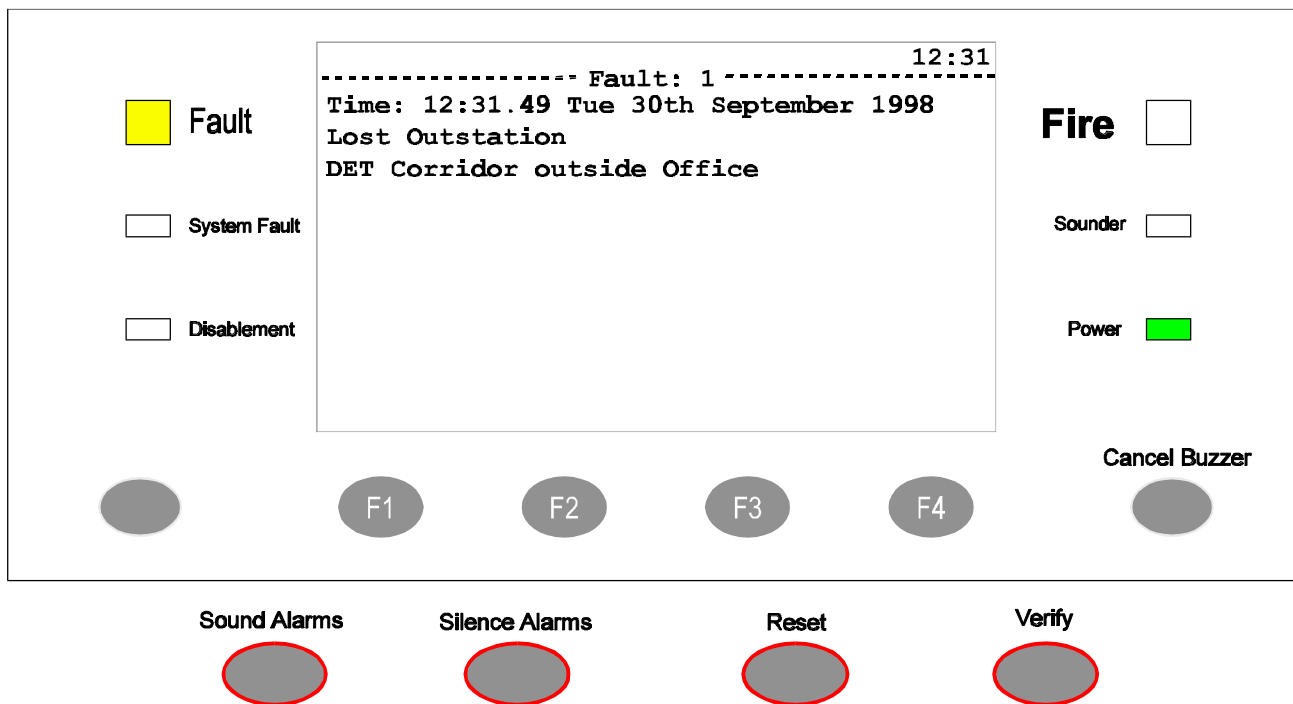

Figure 9 Fault condition indication
cdn344

To cancel Fault Buzzer:

- Press the Cancel Buzzer button.
- Display reads 'Buzzer cancelled'.

To rectify fault:

- Read message
- Take necessary action. All fault repairs to be undertaken by engineers responsible. If necessary contact GENT for advice.
- Record fault in log book.

Multiple faults

The number 'n' following the word 'Fault' located top left on the display denotes the number of faults present in the system.

Each fault is logged in the Historic Events log which can be recalled using the menus, see Viewing Historic Events.

Typical fault messages

The following table shows some of the more typical fault messages that may occur along with their meaning and possible rectification.

NOTE: *The rectification actions must be attempted by a trained engineer. For advice, please call the Servicing organisation.*

Message	Meaning	Action
Mains failed	The mains supply to the control panel has failed	Restore the mains supply to the control panel
Lost Device	The Device is not communicating with the Control Panel via the loop	Check the connections to the device.
Printer Lost	The integral printer is not 'seen' by the control panel.	Check the connections to the printer and check that the paper is feeding correctly.
Sensor out of specification	The device indicated is not functioning correctly	Device needs replacing.
Battery discharged n	The battery supply to the control panel has been fully discharged	Check the battery and replace if necessary
Master Alarm(s) oc or sc n	There is an open or short circuit fault on the master alarm wiring	Check the wiring and remove the fault. Ensure the end-of-line device is connected in the circuit.
Wiring changed short circuit at card n	There is a short circuit on the loop n wiring	Identify the outstation (device) where a cable fault has occurred and remove the fault.
Interface inputs / sc	There is an open or short circuit on the input line of an interface	Locate and remove the wiring fault. Ensure the end-of-line device is connected in the circuit.
Device Mains failed	There is a mains supply failure at an interface unit, repeat panel or a mimic panel.	Check the fuse and mains supply to the equipment.
Device Battery fault	The battery supply at an interface unit, repeat panel or mimic panel has failed the load test	Check the battery and replace it if necessary

Disablement conditions

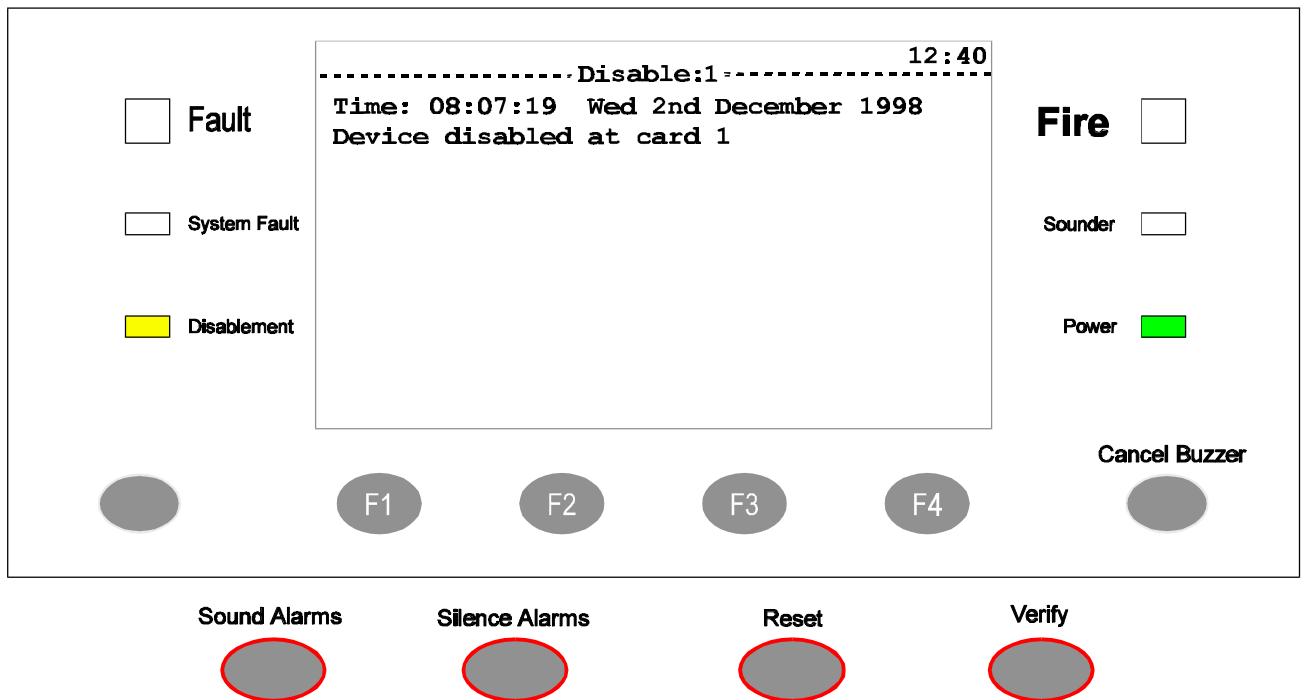

Figure 10 Disablement condition indication
cdn346

To rectify disablement:

- Read message
- Take necessary action. All disablement removals to be undertaken by engineers responsible. If necessary contact your servicing organisation.
- Record event in log book.

Multiple disablements

The number 'n' following the word 'Disablement' fault located top left on the display denotes the number of disablements present in the system.

Each disablement is logged in the Historic Events log which can be recalled using the menus, see Viewing Historic Events.

Typical Disablement Messages

The following table shows some typical disablement messages, along with what they mean and possible rectification actions.

NOTE: *The rectification actions must be attempted by a trained engineer. For advise call the servicing organisation.*

Message	Meaning	Action
Alarm Zone Disabled at Card <i>n</i>	The zone specified has been manually or automatically disabled	If manually disabled then investigate and if necessary re-enable the zone
Device disabled at card <i>n</i>	The device connected to the loop circuit have been manually or automatically disabled	If manually disabled then investigate and, if appropriate, re-enable the device
Sector disabled at card <i>n</i>	The fire alarm sector on loop <i>n</i> has been manually or automatically disabled	If manually disabled then investigate and, if appropriate, re-enable the sectors
Disabled Aux Relay <i>n</i>	The auxiliary relay <i>n</i> in the control panel has been manually or automatically disabled	If manually disabled then investigate and, if appropriate, re-enable the aux relay
Master alarms disabled	The master alarms have been manually or automatically disabled	If manually disabled then investigate and, if appropriate, re-enable the master alarms

Instructions For MENU ON/OFF

The MENU ON/OFF facilities are menu operated, using function keys F1 to F4. The menu prompts are displayed above the function keys to prompt the user to make a selection.

At any level in a menu, successive pressing of the MENU ON/OFF key, aborts an operation. However as an alternative, the [Quit] prompt can be selected to exit the function mode.

If the time taken between key presses exceeds five minutes, the control panel automatically removes the prompt display and shows the system status indications.

The [Params] prompt is a Help function to provide information to the user regarding the type of input data required.

Most of the functions in the [Control], [Setup] and [TestEng] menus, are protected with access code entry. The code is programmed during commissioning of the system and is passed to the site person responsible for the fire alarm system.

***NOTE:** When an access code is not set up, there is an open entry to operate the controls under User Code. In this situation, the instructions for entering access codes should be ignored.*

Testing the Display

- Press the MENU ON/OFF key and then the F4 key to select [TestEng].
- Press the F1 key to select [Disp Test] . Check that the following events occur:
 - The red, green, and four amber lamps are lit for approximately two seconds.
 - The display is cleared for approximately two seconds and then displays a system status message.
 - The buzzer sounds for approximately two seconds.

Setting The System Clock

CAUTION: INCORRECT SETTING OF THE SYSTEM CLOCK AFFECTS THE TIME RELATED SENSOR CONFIGURATION AND ALSO RESULTS IN INCORRECT EVENT TIME INFORMATION

- Press the MENU ON/OFF key and then the F2 key to select [Set Up].
- Press the F4 key to select [User Code].
 - Check that User Code followed by a flashing cursor appears on the screen.
- Press the F1 key to select [Set Clock].
 - The system clock is displayed on the screen. Check that the hour digits are flashing.
- Press the F2 or F3 key to [Retard] or [Advance] to a desired setting.
- Press the F1 key to select [Next].
 - Check that the Minute digits are now flashing.
- Press the F2 or F3 key to [Retard] or [Advance] to a desired setting.
- Press the F1 key to select [Next].
 - Check that the Date digits are now flashing.
- Press the F2 or F3 key to [Retard] or [Advance] to a desired setting.
- Press the F1 key to select [Next].
 - Check that the Month is now flashing.
- Press the F2 or F3 key to [Retard] or [Advance] to a desired setting.
- Press the F1 key to select [Next].
 - Check that the Year is now flashing.
- Press the F2 or F3 key to [Retard] or [Advance] to a desired setting.
- Press the F4 key to select [Enter].
 - Check that the display now shows the new time and date.

NOTE: All equipment displaying the clock and date information will be updated with the new entries.

Using The Printer

- Press the MENU ON/OFF key.
 - Press the F1 key to select [Control] .
 - Press the F3 key to select [Printer] .
 - Check that 'Printer' appears on the screen.
- To Switch On the Printer**
- Press the F3 key to select [On]
 - Press the F2 key to select [Enter].
 - Check that the message 'Printer is on' appears on the display to show that the action has been successfully carried out.
 - Check that the printer provides a listing of this event.
- To Action An Automatic Paper Feed**
- Repeat MENU ON/OFF, F1, and F3
 - Press the F2 key to select [Paper Fd] .
 - Check that the displayed messages and the menu prompts are cleared.
 - Check that the printer performs eight line feeds.
- To Conduct A Printer Test**
- Repeat MENU ON/OFF, F1, and F3
 - Press the F1 key to select [Test] .
 - Check that the displayed messages and the menu prompts are cleared.
 - Check that the printer provides a listing of all the alphanumeric characters it is capable of printing.
- To Switch Off the Printer**
- Repeat MENU ON/OFF, F1, and F3
 - Press the F3 key to select [Off]
 - Press the F2 key to select [Enter] .
 - Check that the message 'Printer is off' appears on the display to show that the action has been successfully carried out.

Enabling or Disabling Parts of the System

WARNING: *Disabling an extinguishant interface outstation does not disable the outstation outputs. Hence the extinguishant agent could be released. However the disabling of the appropriate sectors would prevent outputs operating on fire. Sectors reserved for extinguishant applications can be manually operated using the control menu.*

NOTE: *It is **only** possible to disable a Manual Call Point (MCP) individually, not as part of a range. Disabling an MCP is however, **not** recommended.*

Enable/Disable Zone

There can be up to 128 zones configured in a fire alarm system. The zone operation can be disabled or enabled.

NOTE: *Disabling a zone does not disable manual call points in the zone. Therefore a fire alarm of fire can be raised by operating a call point in a disabled zone.*

- Press the MENU ON/OFF key.
- Press the F1 button to select [Control].
- Press the F4 button to select [UserCode] .
 - Notice a flashing cursor and a message on the display 'Enter access code'.
- Use the keyboard to input your access code and then press the Enter button.

To disable: Press the F2 button to select [Disable] . This puts 'Disable' on the display.

To enable: Press the F1 button to select [Enable] . This puts 'Enable' on the display)

- Press the F4 button to select <etc> and then press the F2 button to select [Zone] .

- Notice 'Zone' appears on the display followed by a flashing cursor.

- Use the keyboard to input a zone number or range (1-128).

- Press the F2 button to select [Enter].

- Notice the action has been processed and a message appears on the display 'Zone n enabled or disabled'. The Disablement light will be lit upon disablement of any system equipment.

Enable/Disable Devices (Sensors, MCPs)

- Press the MENU ON/OFF key.
- Press the F1 button to select [Control].
- Press the F4 button to select [UserCode] .
 - Notice a flashing cursor and a message on the display 'Enter access code'.
- Use the keyboard to input your access code and then press the Enter button.

To disable: Press the F2 button to select [Disable] . This puts 'Disable' on the display.

To enable: Press the F1 button to select [Enable] . This puts 'Enable' on the display.

- Press the F1 button to select [Device].
 - Notice 'Device' followed by a flashing cursor appears on the display.

Use the keyboard to input an outstation number or range (1-200).

Press the F2 button to select [Loop] .

- Notice 'Loop' followed by a flashing cursor on the display.

Use the keyboard to input a loop number or range (1-8).

Press the F2 button to select [Enter].

- Notice the action has been processed and confirmed by a message either: 'Device(s) enabled' or 'Device(s) disabled' . Notice that the Disablement indicator is lit or extinguished as appropriate.

Enable/Disable Input/Output Line(s)

There are up to four input/output lines on an interface unit which can be disabled or enabled.

CAUTION: An output line of an interface unit is normally assigned to a sector. The output line can only be disabled by disabling that sector, which has the affect of also disabling all other devices (Devices) in the sector.

- Press the MENU ON/OFF key.
- Press the F1 button to select [Control].
- Press the F4 button to select [UserCode] .
 - Notice a flashing cursor and a message on the display 'Enter access code'.
- Use the keyboard to input your access code and then press the Enter button.
- To disable:** Press the F2 button to select [Disable] . This puts 'Disable' on the display.
- To enable:** Press the F1 button to select [Enable] . This puts 'Enable' on the display.
- Press the F2 button to select [IO Line] .
 - Notice 'IO Line' followed by a flashing cursor appears on the display.
- Use the keyboard to input IO line number or range (1-4).
- Press the F2 button to select [Device].
 - Notice 'Device' followed by a flashing cursor appears on the display.
- Use the keyboard to input an outstation number or range (1-200).
- Press the F2 button to select [Loop].
 - Notice 'Loop' followed by a flashing cursor on the display.
- Use the keyboard to input a loop number or range (1-8).
- Press the F2 button to select [Enter].
 - Notice the action has been processed and a message appears on the display 'IO line disabled/enabled at Card n'. The disablement lamp light will be lit upon disablement of any system equipment.

Enable/Disable Auxiliary Relays

There are two auxiliary relays in the control panel whose operation can be disabled or enabled.

- Press the MENU ON/OFF key.
- Press the F1 button to select [Control].
- Press the F4 button to select [UserCode] .
 - Notice a flashing cursor and a message on the display 'Enter access code'.
- Use the keyboard to input your access code and then press the Enter button.

To disable: Press the F2 button to select [Disable] . This puts 'Disable' on the display.

To enable: Press the F1 button to select [Enable] . This puts 'Enable' on the display.

Press the F4 button twice to select <etc> and then press the F2 button to select [Aux Rly] .

- Notice 'Aux Rly' followed by a flashing cursor appears on the display.

Use the keyboard to input an auxiliary relay number or range (1-2).

Press the F2 button to select [Enter] . Notice the action has been processed.

- Notice the action has been processed and a message appears on the display 'Aux Rly n disabled/enabled' . The Disablement light will be lit upon disablement of any system equipment.

Enable/Disable Master Alarm

There are two master alarm circuits in the control panel whose operation can be disabled or enabled.

- Press the MENU ON/OFF key.
- Press the F1 button to select [Control].
- Press the F4 button to select [UserCode] .
 - Notice a flashing cursor and a message on the display 'Enter access code'.
- Use the keyboard to input your access code and then press the Enter button.

To disable: Press the F2 button to select [Disable] . This puts 'Disable' on the display.

To enable: Press the F1 button to select [Enable] . This puts 'Enable' on the display.

Press the F4 button twice to select <etc> and then press the F1 button to select [MAAlarm] .

- Notice 'Master Alarms' appears on the display.

- Press the F2 button to select [Enter].
 - Notice the action has been processed and a message appears on the display 'Master sounder disabled/enabled'. The Disablement light will be lit upon disablement of any system equipment .

Enable/Disable Sectors (Sounders, Interface Unit outputs)

There can be up to 32 sectors per loop configured in a fire alarm system. A sector operation can be disabled or enabled.

- Press the MENU ON/OFF key.
- Press the F1 button to select [Control].
- Press the F4 button to select [UserCode] .
 - Notice a flashing cursor and a message on the display 'Enter access code'.
- Use the keyboard to input your access code and then press the Enter button.

To disable: Press the F2 button to select [Disable] . This puts 'Disable' on the display.

To enable: Press the F1 button to select [Enable] . This puts 'Enable' on the display.

- Press the F3 button to select [Sector] .
 - notice 'Sector' appears on the display followed by a flashing cursor.
- Use the keyboard to input a sector number or range (1-32).
- Press the F2 button to select [Loop] .
 - Notice 'Loop' followed by a flashing cursor on the display.
- Use the keyboard to input a loop number or range (1-8).
- Press the F2 button to select [Enter] .
 - Notice the action has been processed and a message appears on the display 'Card n set up'. The Disablement light will be lit upon disablement of any system equipment.

Other Enable/Disable options

Similarly it is possible to enable or disable Command Builds, Groups, Master Sector and Communications.

Viewing Active Events

To view all active Faults, Disablements, Warnings and Supervisories.

- Press MENU ON/OFF.
- Press the F3 button to select [Info].

To display the event(s):

- Press the F1 button to select [Display].

- Notice 'Display' appears on the display.

To print the event(s):

- Press the F2 button to select [Print]

- Notice 'Print' appears on the display.

NOTE: With the printer switched Off, print procedures are not applicable

- Press the F1 button to select [Active]
 - Notice 'Active' followed by a flashing cursor appears on the display.
- Press the F2 button to select [Enter]
 - Notice all of the active Faults, Disablements, Warnings and Supervisories will be displayed in turn.
- Use F2 [Previous] and F3 [Next] to scroll through the events
- Press the F4 button to select [Quit] when the events viewing is complete.

Viewing Historic events

Up to 255 events are stored in the Historic log. To view the Historic log.

- Press MENU ON/OFF.
- Press the F3 button to select [Info].

To display the event(s):

- Press the F1 button to select [Display].

- Notice 'Display' appears on the display.

To print the event(s):

- Press the F2 button to select [Print]

- Notice 'Print' appears on the display.

NOTE: *With the printer switched Off, print procedures are not applicable*

- Press the F2 button to select [Historic]

- Notice 'Historic' followed by a flashing cursor appears on the display.

- Use the keyboard to input an event number or range (1-255).

NOTE: *Event 1 is the most recent event.*

- Press the F2 button to select [Enter]

- Notice all of the active Faults, Disablements, Warnings and Supervisories will be displayed in turn.

Saving changes to the Memory Card

Any changes made to Labels or Password should be saved in the Memory Card.

- Press the MENU ON/OFF button.
- Press the F2 button to select [Set Up] .
- Press the F4 button to select [UserCode].
 - Notice a flashing cursor and a message on the display 'Enter access code'.
- Use the full keyboard to input your access code and then press the Enter button.
- Press the F4 button four times to select <etc>.
- Press the F3 button to select [Protect] .
- Press the F3 button to select [Disable] .
- Press the F2 button to select [Enter] .
- Press the F1 button to select [Backup] .
 - Notice 'Backup data from card' followed by a flashing cursor appears on the display.
- Use the keyboard to input a card number or range (0-15).
- Press the F2 button to select [RAMCard].
 - Notice 'Data from card 'n' to RAMCard' appears on the display where n = card number .
- Press the F2 button to select [Enter].
- Observe confirmation messages as each card is backed up.
- Press the F3 button to select [Protect] .
- Press the F3 button to select [Enable] .
- Press the F2 button to select [Enter] .

NOTE: The changes can only be backed up to Memory Card if no disablements are present on the system.

Changing the UserCode Password

A password is required to gain access to options under [UserCode] . A new password can be created or a previously created one can be changed.

A password access prevents unauthorised use of options under [UserCode] , that exist in the [Control], [Set Up] , [Info] and [Test/Eng] menus.

NOTE: *The password can be up to 15 characters in length..*

- Press the MENU ON/OFF button.
- Press the F4 button to select [Test/Eng].
- Press the F4 button to select [UserCode].
- Use the keyboard to input your existing access code and then press the Enter button.
- Press the F4 key to select <etc>, repeat until [NewPass] is displayed above F1.
- Press the F1 button to select [New Pass].
 - Notice a message on the display 'Enter new access code' with a flashing cursor above it.
- Use the keyboard to input a new access code and then press the Enter button.
 - Notice 'New access code set up' appears on the display.

NOTE: *Changes to the User Code password at the Control panel is stored on Card O, the card must therefore be backed-up to the Memory Card. If this is not done then the previous password will be restored when a reset is performed.*

NOTE: *It is not necessary to backup the passwords at repeat panel and terminal node.*

Labelling

Editing Label Information

NOTE: Changes or entry of label should be backed up to the Memory Card., see Saving Changes to the Memory Card

Device Label

A Device is a system device like a fire sensor, manual call point, interface unit, repeat panel or alarm sounder.

- Press the MENU ON/OFF button
- Press the F2 button to select [Set Up].
- Press the F4 button to select [UserCode] .
 - Notice a message on the display 'Enter access code', followed by a flashing cursor.
- Use the keyboard to input access code and then press Enter button.
- Press the F4 button once to select <etc>
- Press the F1 button to select [Modify]
 - Notice 'Modify' appears on the display.
- Press the F1 button to select [Label]
 - Notice 'Label' appears on the display.
- Press the F3 button to select [Device].
 - Notice 'Device' followed by a flashing cursor appears on the display.
- Use the keyboard to input a Device number or range (1-200).
- Press the F2 button to select [Loop].
 - Notice 'Loop' followed by a flashing cursor on the display.
- Use the full keyboard to input a loop number or range (1-8).
- Press the F2 button to select [Enter].
- Notice the previous label appears on the display with a flashing first character to prompt the modification.

Input/Output Line label

Each input/output line of an interface unit can be given a label and a previously entered label can be modified.

- Repeat MENU ON/OFF, F2, F4, USER CODE + ENTER, F4, F1 and F1
- Press the F2 button to select [IO Line].
 - Notice 'IO Line' followed by a flashing cursor on the display.
- Using the keyboard enter an input/output number or range (1-4).
- Press the F3 button to select [Device].
 - Notice 'Device' followed by a flashing cursor appears on the display.
- Use the keyboard to input a Device number or range (1-200).
- Press the F2 button to select [Loop].
 - Notice 'Loop' followed by a flashing cursor on the display.
- Use the full keyboard to input a loop number or range (1-8).
- Press the F2 button to select [Enter].
- Notice the previous label appears on the display with a flashing first character to prompt the modification.

Zone label

Each zone can be given a label and an entered label can be modified.

- Repeat MENU ON/OFF, F2, F4, USER CODE + ENTER, F4, F1 and F1
- Press the F4 button once to select <etc>.
- Press the F1 button to select [Zone].
 - Notice 'Zone' followed by a flashing cursor appears on the display.
- Using the keyboard enter a number or range (1-128).
- Press the F2 button to select [Enter].
- Notice the previous label appears on the display with a flashing first character to prompt the modification.

Local panel label

Each control panel and terminal node in a network can be given a label and a previously entered label can be modified.

- Repeat MENU ON/OFF, F2, F4, USER CODE + ENTER, F4, F1 and F1
- Press the F4 button once to select <etc>.
- Press the F2 button to select [Local].
 - Notice 'local' appears on the display.
- Press the F2 button to select [Enter].
- Notice the previous label appears on the display with a flashing first character to prompt the modification.

Viewing Labels

The identification label given to each system device, such as a Device like a fire sensor, alarm sounder, manual call point, repeat panel, and interface unit - including input/output lines, plus group and local panel labels can be checked. The information can either be displayed or printed.

NOTE: With printer switched Off, step b) and PRINT procedures are not applicable.

Device Label

- Press the MENU ON/OFF button
- Press the F3 button to select [Info].
- To display a Device label:**
 - Press the F1 button to select [Display].
 - Notice 'Display' appears on the display.
- To print a Device label:**
 - Press the F2 button to select [Print] .
 - Notice 'Print' on the display
- Then continue**
 - Press the F4 button to select <etc>
 - Press the F2 button to select [Label] .
 - Notice 'Label' appears on the display.
 - Press the F3 button to select [Device] .
 - Notice 'Device' followed by a flashing cursor appears on the display.
 - Use the full keyboard to input an Device number or range (1-200).
 - Press the F2 button to select [Loop] .
 - Notice 'Loop' followed by a flashing cursor appears on the display.
 - Use the full keyboard to input a loop number or range (1-8).
 - Press the F2 button to select [Enter] .
 - Notice the selected label information is either displayed or printed.

Input/Output line Label

An interface unit has four input/output lines. Each line can be given a label that appears on the display during an event.

- Press the MENU ON/OFF button
- Press the F3 button to select [Info].
- To display a I/O line label:**
 - Press the F1 button to select [Display].
 - Notice 'Display' appears on the display.
- To print a I/O line label:**
 - Press the F2 button to select [Print].
 - Notice 'Print' on the display
- Then continue**
 - Press the F4 button to select <etc>
 - Press the F2 button to select [Label].
 - Notice 'Label' appears on the display.
 - Press the F2 button to select [IO Line].
 - Notice 'IO Line' followed by a flashing cursor on the display.
 - Use the keyboard to enter an input/output number or range (1-4).
 - Press the F2 button to select [Device].
 - Notice 'Device' followed by a flashing cursor on the display.
 - Use the full keyboard to input a Device number or range (1-200).
 - Press the F2 button to select [Loop].
 - Notice 'Loop' followed by a flashing cursor appears on the display.
 - Use the full keyboard to input a loop number or range (1-8).
 - Press the F2 button to select [Enter].
 - Notice the selected label information is either displayed or printed.

Zone label

- Press the MENU ON/OFF button
- Press the F3 button to select [Info].
- To display a Zone label:**
 - Press the F1 button to select [Display].
 - Notice 'Display' appears on the display.
- To print a Zone label:**
 - Press the F2 button to select [Print].
 - Notice 'Print' on the display
- Then continue**
 - Press the F4 button to select <etc>
 - Press the F2 button to select [Label].
 - Notice 'Label' appears on the display.
 - Press the F4 button once to select <etc>.
 - Press the F1 key to select [Zone]
 - Notice 'Zone' followed by a flashing cursor appears on the display.
 - Use the full keyboard to input a Zone number or range (1-128).
 - Press the F2 key to select [Enter].
 - Notice the selected label information is either displayed or printed.

Local Panel label

- Press the MENU ON/OFF button
- Press the F3 button to select [Info].
- To display a local panel label:**
 - Press the F1 button to select [Display].
 - Notice 'Display' appears on the display.
- To print a local panel label:**
 - Press the F2 button to select [Print] .
 - Notice 'Print' on the display
- Then continue**
 - Press the F4 button to select <etc>
 - Press the F2 button to select [Label] .
 - Notice 'Label' appears on the display.
 - Press the F4 button once to select <etc> .
 - Press the F2 key to select [Local] .
 - Notice 'Local' appears on the display.
 - Press the F2 key to select [Enter].
 - Notice the selected label information is either displayed or printed.

Removing and changing devices

CAUTION: The procedures described in this section can leave parts of the system unoperational. Therefore it is recommended that the procedures only be carried out by a suitably trained person, such as your Servicing organisation.

System Modifications

Removing devices temporarily

Prior to removing any device(s), the loop must be powered down.

Powering down a loop

- Press the MENU ON/OFF button
- Press the F4 button to select [Test/Eng] .
- Press the F4 button to select [User code] .
 - Notice a message on the display 'Enter access code' followed by a flashing cursor.
- Use the keyboard to input your access code and then press the Enter button.
- Press F3 to select [Reset] .
- Press F2 to select [loop] .
 - Notice 'loop' followed by a flashing cursor on the display.
- Use the keyboard to enter the loop number.
- Press Enter and within 2 seconds press MENU ON/OFF. the loop is now powered down.

The device(s) can now be removed as required. After the devices are removed the loop must be reallocated.

CAUTION: The location of each device **must be recorded carefully** so that the device can be replaced in its **correct location**.

Reallocation procedure

- Press the MENU ON/OFF button.
- Press the F4 button to select [Test/Eng] .

- Press the F4 button to select [User code] .
 - Notice a message on the display 'Enter access code' followed by a flashing cursor.
- Use the keyboard to input your access code and then press the Enter button.
- Press F1 to select [Allocate] .
- Press F2 to select [loop].
 - Notice 'loop' followed by a flashing cursor on the display.
- Use the keyboard to enter the loop number and press Enter.

Upon completion of the loop allocation, there will be a 'RAM card recovery failure' warning. This cannot be cancelled, but does not prevent the system working as normal.

Replacement of Removed devices

To replace the device(s) removed:

- Power down the loop.
- The removed device(s) can now be replaced.
- After the devices have been replaced, the loop must be reallocated.

NOTE: *The configuration data including the labels, for the removed devices is not lost, only map information changes. This allows the change to be reversed if required.*

Changing devices

Swapping chamber only.

Swapping the chamber of a device is performed as normal. This will not affect the device’s SAFE address.

Changing the device’s electronic module.

- Power down the loop.
- The faulty device(s) can now be removed and replaced as required.
- After the devices have been replaced the loop must be reallocated.
- Upon allocating the loop various uncancellable warnings will be generated. These are given in the following table:

		Same device type	Different device type
No SAFE address set up	Warning/fault displayed	‘Outstation SAFE address not set’ ‘Device Y Loop Z’	‘Replaced outstation wrong type’
	Action to resolve	Procedure 1	Procedure 2
SAFE address set Up	Warning/fault displayed	‘Outstation soft addressed; SAFE: X’ ‘Device Y Loop Z’	‘Replaced outstation wrong type’
	Action to resolve	Procedure 1	Procedure 2
Duplicate SAFE address	Warning/fault displayed	‘Duplicate SAFE address error: X’ ‘Device Y Loop Z’	‘Replaced outstation wrong type’
	Action to resolve	Procedure 1	Procedure 2

NOTE: If the loop is reallocated before the SAFE address is changed, a loop map changed event is generated.

- Procedure 1** Set up the SAFE address at the panel as given in ‘Configuring a SAFE address’ detailed in this chapter.
- Procedure 2** Reallocate the loop.
- Set up the SAFE address at the panel as given in ‘Configuring a SAFE address’ detailed in this chapter.

Configuring a SAFE address

- Press the MENU ON/OFF button
- Press the F4 button to select [Test/Eng] .
- Press the F4 button to select [User code] .
 - Notice a message on the display 'Enter access code' followed by a flashing cursor.
- Use the keyboard to input your access code and then press the Enter button.
- Press the F4 button to select <etc> .
- Repeat operation until [SAFE] is displayed above F1.
- Press the F1 button to select [SAFE].
 - Notice a message on the display 'SAFE' followed by a flashing cursor.
- Use the keyboard to enter the address of the device(s) to set as SAFE addressed device(s).

NOTE: The addresses may be entered as a range if they are consecutive addresses.

- Press the F2 button to select [Loop] .
 - Notice a message on the display 'Loop' followed by a flashing cursor.
- Use the keyboard to enter the loop number on which the device(s) are located.
- Press the F2 button to select [Address] .
 - Notice a message on the display 'Address' followed by a flashing cursor.
- Use the keyboard to enter the new SAFE address(es) of the device(s)
- Press the F2 button to select [Enter] to make the change.

The loop map denotes all SAFE addresses with a '+', see following sample printout.

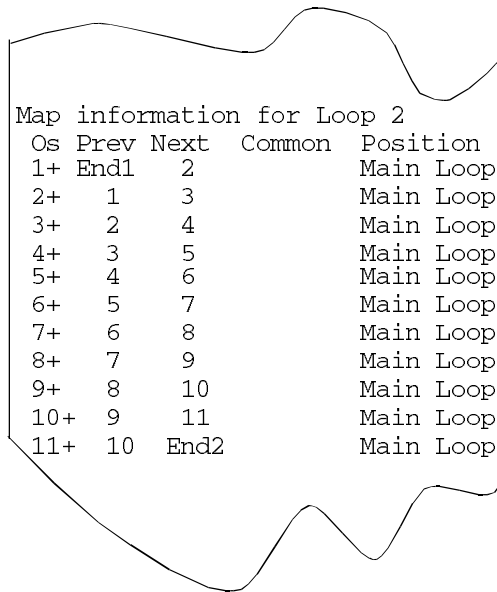

Figure 11 Sample printout

cdn108

To print out a loop map

If printer is off

- Press the MENU ON/OFF button
- Press the F1 button to select [Control] .
- Press the F4 button to select [User code] .
 - Notice a message on the display ‘Enter access code’ followed by a flashing cursor.
- Use the keyboard to input your access code and then press the Enter button.
- Press the F4 button to select <etc> . Repeat operation until [Printer] is displayed above F1.
- Press the F3 button to select [On].
- Press the F2 button to select [Enter] . The printer is now on.

To print loop map

- Press the MENU ON/OFF button
- Press the F2 button to select [Information] .
- Press the F2 button to select [Print] .
- Press the F4 button to select <etc> . Repeat operation until [Loop Map] is displayed above F2.
- Press the F2 button to select [Loop Map] .
 - Notice ‘Loop Map’ followed by a flashing cursor on the display.
- Use the keyboard to enter the loop number and press F3 to Enter.

Error messages and solutions

1. If during allocation duplicate SAFE addresses are discovered, allocation will continue until complete. The first outstations primary address is changed to the next available soft address. The following uncancelable message will be displayed:

‘Duplicate SAFE address error:X’
‘Device Y Loop Z’

Where X is the shared address and Y is the soft address given to the first outstation.

To resolve this, all duplicate SAFE addresses must be reset using the command in the panel, see ‘Configuring a SAFE address’ and then re-allocate the loop as follows:

- Press the MENU ON/OFF button
- Press the F4 button to select [Test/Eng] .
- Press the F4 button to select [User code] .
 - Notice a message on the display ‘Enter access code’ followed by a flashing cursor.
- Use the keyboard to input your access code and then press the Enter button.
- Press F1 to select [Allocate] .
- Press F2 to select [loop] .
 - Notice ‘loop’ followed by a flashing cursor on the display.
- Use the keyboard to enter the loop number and press Enter. .

2. It is possible to set duplicate addresses via the panel. This will generate the following uncancelable warning:

‘Duplicate SAFE address error :X’
‘Device Y Loop Z’

The solution is as for 1.

Vigilon system parts

Introduction

This section lists parts used in the Vigilon system. For further details on the availability of the parts, contact GENT.

Control and indicating equipment

* - First fix products

Control Panels	VIG -1ST-FIX*	Control panel backbox + Battery box
	VIG1 -V3+	Control panel (V3+) c/w 1 loop card
	VIG1	Control panel c/w 1 loop card (EN54)
	VIG2 -V3+	Control panel (V3+) c/w 2 loop cards
	VIG2	Control panel c/w 2 loop cards (EN54)
	VIG3 -V3+	Control panel (V3+) c/w 3 loop cards
	VIG3	Control panel c/w 3 loop cards (EN54)
	VIG4 -V3+	Control panel (V3+) c/w 4 loop cards
	VIG4	Control panel c/w 4 loop cards (EN54)
	VIG1-NET -V3+	Control panel (V3+) c/w 1 loop card and Network card
	VIG1-NET	Control panel c/w 1 loop card and Network card (EN54)
	VIG2 -NET-V3+	Control panel (V3+) c/w 2 loop cards and Network card
	VIG2 -NET	Control panel c/w 2 loop cards and Network card (EN54)
	VIG3 -NET-V3+	Control panel (V3+) c/w 3 loop cards and Network card
	VIG3 -NET	Control panel c/w 3 loop cards and Network card (EN54)

VIG4 -NET-V3+	Control panel (V3+) c/w 4 loop cards and Network card
VIG4 -NET	Control panel c/w 4 loop cards and Network card (EN54)

NOTE: The Control Panel is supplied as two parts, ie VIG-1ST-FIX and VIGx-V3+ OR VIGx-NET_V3+ where x =1,2,3 or 4.

Control panel software	VIG-SOFT-COIN	Coincidence detection
	VIG-SOFT-INFO	Site wide fire information
Control panel accessories	VIG-FLUSH	Control panel flush surround
	VIG-RACK	Control panel 19" Rack mounting bracket
	VIG-WR-CASE	Control panel weather resistant case
Network Node	VIG-NODE-V3+	Network node
	VIG-NODE	Network node (EN54)
Repeat panel	VIG-RPT-1ST-FIX	Repeat Panel Backbox
	VIG-RPT-V3+	Repeat panel (V3+)
	VIG-RPT	Repeat panel (EN54)

NOTE: The Repeat Panel is supplied as two parts, ie VIG-RPT-1ST-FIX and VIG-RPT.

Mimic panels	VIG-MIM	Mimic panel c/w drawing
	VIG-ZONE	Zonal mimic panel
	VIG-MIM-A4	A4 Mimic Panel
	VIG-ZONE-A4	A4 Zonal Mimic Panel
Spares	VIG-BATT	Spare control panel battery box
	VIG-BATT-RPT	Spare repeat/mimic panel battery pack
	VIG-PAPER	Spare printer roll Mtp 401
Extra cards	VIG-LCC-V3+	Local controller card
	VIG-LCC	Local controller card (EN54)

VIG-LCC-NODE	Local controller card for network node (EN54)
VIG-LPC-V3+	Loop Card
VIG-LPC	Loop Card (EN54)
VIG-RAM	RAM Card
VIG-NC-V3+	Network card
VIG-NC	Network card (EN54)
VIG-IOC-V3+	Input/Output card
VIG-IOC	Input/Output card (EN54)
VIG-IOC-UNI-V3+	Universal Communications Input/Output card
VIG-IOC-UNI	Universal Communications Input/Output card (EN54)
VIG-IOC-PRT-V3+	Remote printer input/output card
VIG-IOC-PRT	Remote printer input/output card (EN54)

Sensors and Accessories

Sensors	VIG-SEN-OH	Optical heat sensor
	19271-01	Optical chamber
	VIG-SEN-OH-RL	Optical heat sensor with Remote LED connection
	VIG-REM-LED	Remote LED
	VIG-SEN-OH-ML	Optical heat sensor with MCP connection (Chinese market only)
	VIG-SEN-OHS	Optical heat sensor sounder
	19271-01	Optical chamber
	VIG-SEN-HS	Heat sounder
	19274-01	Heat sounder chamber
	VIG-SEN-H	Heat sensor
	19272-01	Heat chamber

	VIG-SEN-I	Ionisation sensor <R>
	19273-01	Ionisation chamber
	VIG-SEN-H-EP	Environmentally protected Heat sensor
	VIG-BEAM	Beam sensor pair
	VIG-BEAM-ANG	Angle bracket with base
	VIG-BEAM-ANG-IP	IP65 Angle bracket with base
	VIG-BEAM-PAR	Parallel bracket with base
	07012-31	Conventional Flame detector
	VIG-SEN-DUCT	Duct sensor (inc 17908-05 Probes & VIG-SLV-LED Slave LED unit)
Tools	17918-22	Sensor chamber Extractor cup
	17918-23	Optical chamber electronics module removal tool
	17918-24	Ionisation chamber electronics module removal tool
	17918-25	Heat sensor electronics module removal tool
	17918-26	Sensor removal tool kit
Terminal Plate	VIG-SEN-TERM	3-way terminal plate
	VIG-SEN-TERM-4	4-way terminal plate
	19279-01	Semi-flush sensor mounting kit
	07700-21	Base for Conventional flame detector
T Breaker and Slaves	VIG-T	T breaker Unit
	VIG-SLV-LED	Slave LED unit
	VIG-SLV-RLY	Slave Relay unit
Alarm sounders	VIG-SND	Sounder
	VIG-SND-T	Sounder T-Breaker
	VIG-SND-T-EP	Environmentally protected Sounder T-Breaker

VIG-SND-RPT	Repeat sounder (VIG-SEN-TERM required)
-------------	---

Manual call points (MCP) 2-way

	VIG-MCP	Surface mounted MCP
	VIG-MCP-KEY	Surface mounted keyswitch MCP
	VIG-MCP-CVR	Surface mounted MCP with cover
	VIG-MCP-WR	Surface mounted water resistant MCP
	19289-01	MCP flush fixing plate
	VIG-MCP-WR-CVR	Surface mounted water resistant MCP with cover
	VIG-MCP-EP	Environmentally protected surface mounted MCP
Spares	13480-09	Spare MCP glasses 10 pack for LPCB approved
	14112-09GR	Spare MCP glasses 10 pack non LPCB approved

Interfaces

Mains powered	VIG-INT-MAINS	Mains powered fire alarm interface
	19104-52	Power relay (for mains powered interface) (up to 4 maximum can be used - supplied with base and diode)
4- Channel Loop powered	VIG-INT-LOOP	Loop powered fire alarm interface
	19245-05	Interface line module -up to 4 can be fitted in a loop powered fire alarm interface
1- Channel Loop powered	VIG-INT-KEY	4 way keyswitch door for loop powered interface
	VIG-INT-ZONE	Loop powered zone module
	VIG-INT-1CH	Single Channel Interface (Loop Powered)
	19245-05	Interface line module

Rack	VIG-RACK-BOX	Rack interface back box
	VIG-RACK	Rack interface
	VIG-RACK-DOOR	Interface rack door
	VIG-RACK-TERM	4 way interface line module assembly
	VIG-RACK-PCB	Interface rack PCB 4-way
Keyswitches	19245-02	2 position keyswitch assembly (for use with optional interface doors)
	19245-03	3-position keyswitch assembly (for use with optional interface doors)
	13445-40	Interface card (loop powered) (up to 10 used in 13445-05 rack interface)
Power supply Unit	19245-06	Power supply unit with 1 relay (for use with loop powered interface unit)
	19245-07	Mains relay (up to 4 for use with 19245-06 unit)
Fix Extinguishant	VIG-INT-FE	Loop powered fixed extinguishant interface

Manuals & Accessories

VIG-MAN-INS	Vigilon Installation manual
VIG-MAN-OPS-V3+	Vigilon V3+ Operator Manual
13563-011	GENT Supervisor Operator Manual

GENT Supervisor

Hardware and Software packages	SUP-TEXT-INFO-DT	Supervisor Text Information only, Desktop
	SUP-TEXT-INFO-TW	Supervisor Text Information only, Tower
	SUP-TEXT-INFO-TS	Supervisor Text Information only, Touchscreen
	SUP-TEXT-FULL-DT	Supervisor Text Full access, Desktop
	SUP-TEXT-FULL-TW	Supervisor Text Full access, Tower
	SUP-TEXT-FULL-TS	Supervisor Text Full access, Touchscreen

	SUP-GRAPH-INFO-DT	Supervisor Graphics Information only, Desktop
	SUP-GRAPH-INFO-TW	Supervisor Graphics Information only, Tower
	SUP-GRAPH-INFO-TS	Supervisor Graphics Information only, Touchscreen
	SUP-GRAPH-FULL-DT	Supervisor Graphics Full access, Desktop
	SUP-GRAPH-FULL-TW	Supervisor Graphics Full access, Tower
	SUP-GRAPH-FULL-TS	Supervisor Graphics Full access, Touchscreen
Software only packages	SUP-TEXT-INFO	Supervisor Text Information only (Software only)
	SUP-TEXT-FULL	Supervisor Text Full access (Software only)
	SUP-GRAPH-INFO	Supervisor Graphics Information only (Software only)
	SUP-GRAPH-FULL	Supervisor Graphics Full access (Software only)
Supervisor Graphics pages	13563-G001	Supervisor graphics page
Supervisor ancillary items	13563-03	Supervisor text printer
	13563-04	Supervisor graphics printer
	13547-14	UPS Netpro 1500VA (70 min standby)
	13563-01	Supervisor modem pair
	13563-02	Supervisor convertor RS232/485

INDEX

A

Automatic detection 12 - 13

B

Basic Maintenance

 manual call point 7

 Replacing a broken Glass 7

 Replacing Printer Paper 8

Battery 6

BS5839 5

C

Cancel Buzzer 14

Changing the User Code Password 31

Control Panel

 LCD display 4

 lights 4

Controls

 Cancel Buzzer 11

 F1-F4 10

 Fire 11

 Menu On/Off 10

 Qwerty keypad 11

 Reset 11

 Silence alarms 11

 Sound alarms 11

 U1-U4 11

 Verify 11

Controls and Indicators

 Description 10 - 11

 First level controls 9

 Normal Condition 11

D

Disablement conditions 16

 Multiple disablements 16

Disabling 5

 Zone 21

 Auxiliary Relays 24

 Input/Output Line(s) 23

 Master Alarm 25

 Devices 19 - 25

 Sectors 26

Display		
Testing		18
E		
Editing Label Information		
Device Label		32
Zone label		34
Input/Output Line label		33, 37
Local panel label		35
Emergency Conditions		12 - 17
Enabling		
Zone		21
Auxiliary Relays		24
Input/Output Line(s)		23
Master Alarm		25
Outstations		22
Sectors		26
F		
Fault conditions		
Cancel Buzzer		14
Multiple faults		14
FIRE		
Automatic detection		12 - 13
Multiple fires		13
Reset		12
silence alarms		12
I		
Indicators		
Disablement		10
Fault		10
Fire		10
Power		10
Sounder		10
System Fault		10
K		
Keyboard		4
L		
Labelling		
Editing Label		32 - 35
Viewing Labels		36 - 39

M

Manual Call Point	6
Replacing a broken Glass	7
manually raise an alarm	12
Memory Card, Saving changes to	30
MENU ON/OFF	18 - 31
Menu Options	
[Disable]	21 - 27
[Enable]	21 - 27
Multiple faults	15
Multiple fires	13

N

Normal condition	11
------------------	----

P

Paper roll	8
Printer	
Automatic Paper Feed	20
Printer Test	20
Replacing Printer Paper	8
Switch Off	20
Switch On	20

R

Removing and Changing devices	40 - 45
Changing devices	42
Configuring	43 - 45
loop map	44
System Modifications	40 - 42
Removing devices temporarily	40
Replacement of Removed devices	41
Error messages and solutions	45

S

Saving changes to the Memory Card	30
System Clock	5, 19

U

UserCode Password, Changing	31
User Responsibility	
Battery Replacement	6
BS 5839:Part 1:1988	5
BS 5839:Part 4:1988	5
Daily	5
Manual Call Point	6
Quarterly	6
Weekly	5

V

Verify	
Multiple fires	13
View labels	36
Viewing Active Events	28
Viewing Historic events	29
Viewing Labels	
Device Label	36
Zone label	38
Input/Output line Label	37
Local Panel label	39

