



Anti-static handling guidelines

Make sure that electrostatic handling precautions are taken immediately before handling PCBs and other static sensitive components.

Before handling any static-sensitive items, operators should get rid of any electrostatic charge by touching a sound safety earth. Always handle PCBs by their sides and avoid touching any components.

1 Installation

1.1 Mounting The Unit

The phone plate can be removed from the back box by removing the screw marked A in the diagram on the right. The phone plate can then be simply lifted free.

The phone can be removed by unclipping the grey connector at the hook switch end of the cable.

The back box can now be prepared for the cable from the EVC System, this is a 2-core 1.5mm CSA Enhanced fire rated cable.

Knock out the cable knock out and gland the cable to the top right of the box. If you are coming in from the rear, drill where indicated by the dotted lines below, this is the only place clear of all operational parts of the outstation. A rubber grommet or gland should be used to protect the cable.

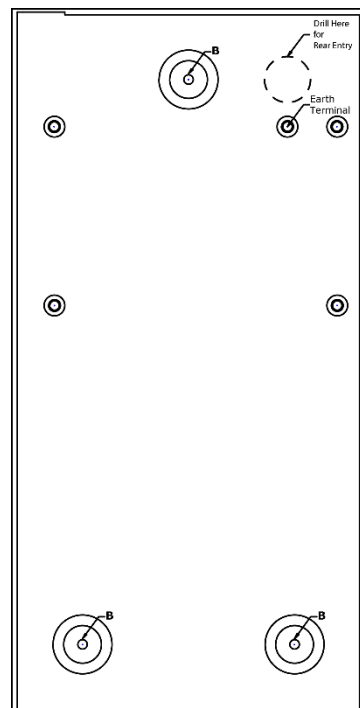

The Back box can now be mounted by using the holes marked B, the height of the unit needs to be 1300 to 1400mm from finished floor level to the centre of the outstation (as shown below).

If flush mounting using the EVCS-OBZ-R bezel, the unit wants fitting to a maximum depth of 95mm for correct opening of the door.

The bezel is attached to the wall using clear bathroom sealer.

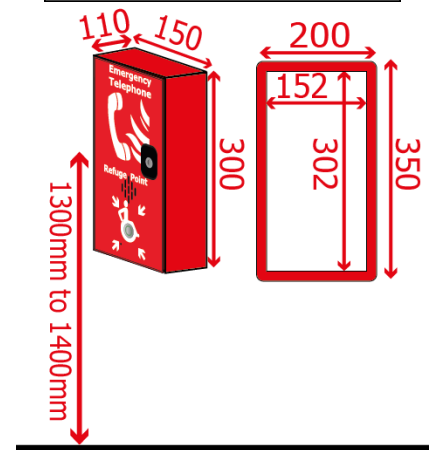
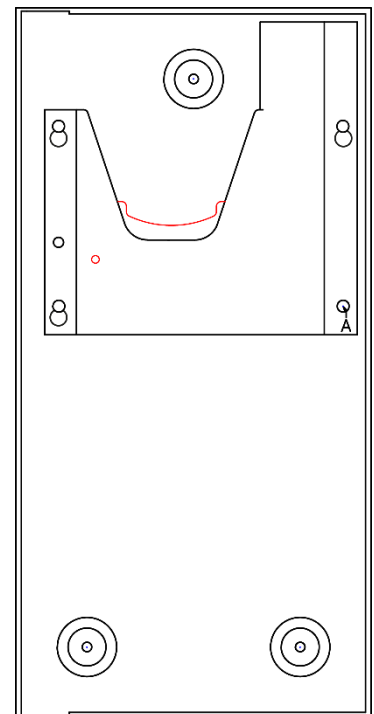
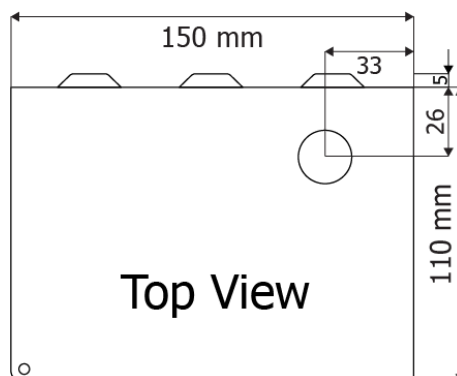

1.2 Connections

The 2 core Enhanced cable should be connected to the Line + and – terminals as shown (the connector is a two part one so it can be removed and terminated before being plugged onto the board).

The Earth should be connected to the Earth terminal in the back box.

The end of line device is pre-fitted in the EOL terminals on the Type B on the door.

The phone plate can be reassembled, and the phone plugged into the grey connector (care should be taken when plugging this in to ensure it is the correct way round).

When the phone is correctly wired the confidence LED lights dimly when the phone is on hook and the button on the type B flashes Green.

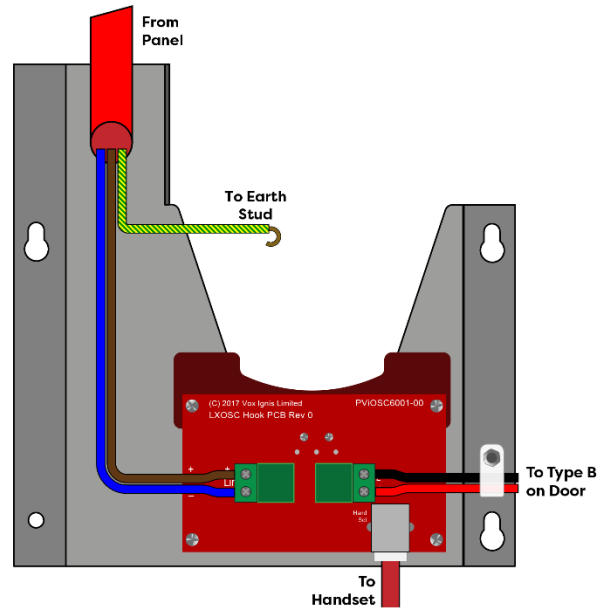

2 Operation

To call from the Type A phone simply remove the phone from the hook switch, this will cause all masters programmed for this line to ring. The call can be ended by placing the phone back on the hook switch (the confidence LED also lights again). To call from the type B press the button on the type B. To end the call press the button again.

When the master calls, the type B outstation ringer sounds and the button flashes RED, to answer either push the button or lift the phone handset from the cradle and speech can take place- To end simply place the phone on the hook switch. The phone overrides the type B when lifted from the hook switch.

3 Maintenance

It is a requirement of BS 5839-9:2021 that a maintenance agreement be in place for the EVCS. The maintenance schedule should be as follows:

Frequency	Test
Weekly	Each week test one type A outstation (a different one each week) and ensure speech is clear and intelligible. Ring the outstation to verify the operation of the ringer. Record this in the logbook for the EVCS.
6 Monthly	Every outstation on the system should be tested and the results logged in the logbook.

Honeywell



WEEE
Compliant
Product

EVCS-VRC | Rev1
01/26 2026 Honeywell

