

Installation Instruction Venturi-Air Duct Kit

(Part No. S4-34760)

Intended purpose

This product is designed for installation on a loop circuit of a Vigilon system.

Warning

In order to ensure correct and safe operation of the product, all guidelines must be observed.

Safety-relevant user information

This manual includes all information required for the proper use of the products described.

The term 'qualified personnel' in the context of the safety information included in this manual or on the product itself designates:

- project engineers who are familiar with the safety guidelines concerning fire alarm and extinguishing systems.
- trained service engineers who are familiar with the components of fire alarm and extinguishing systems and the information on their operation as included in this manual.
- trained installation or service personnel with the necessary qualification for carrying out repairs on fire alarm and extinguishing systems or who are authorised to operate, ground and label electrical circuits and/or safety equipment/systems.

Safety warnings

The following information is given in the interest of your personal safety and to prevent damage to the product described in this manual and all equipment connected to it.

Safety information and warnings for the prevention of dangers putting at risk the life and health of user and maintenance personnel as well as causing damage to the equipment itself are marked by the following pictograms. Within the context of this manual, these pictograms have the following meanings:



Warning sign

Designates risks for man and/or machine. Non-compliance will create risks to man and/or machine. The level of risk is indicated by the word of warning:



Important information on a topic or a procedure and other important information!

Table of contents

| | | |
|-----|--|----|
| 1 | General | 4 |
| 2 | Mounting..... | 4 |
| 2.1 | Mounting the air duct kit | 5 |
| 2.2 | Calculation of upstream and downstream distances | 6 |
| 2.3 | Mounting → Venturi tubes up to 600 mm | 8 |
| 2.4 | Mounting → Venturi tubes between 600 mm and 2800 mm..... | 9 |
| 2.5 | Adapt the Venturi tube length | 10 |
| 2.6 | Mounting the Venturi tube..... | 10 |
| 2.7 | Mounting kit for circular and insulated air ducts..... | 11 |
| 3 | Opening the enclosure..... | 12 |
| 3.1 | Detector base wiring | 12 |
| 3.2 | Install fire detector | 13 |
| 4 | Final check | 14 |
| 5 | Maintenance..... | 15 |
| 6 | Specifications | 16 |
| 7 | Accessories | 16 |
| 8 | Loop Wiring | 17 |

**Additional and updated Information**

The described features, specifications and product related information in this manual correspond to the date of issue (refer to date on the back page).

1 General

The air duct kit (Part No. S4-34760) is used in combination with different Venturi tubes and special S-Quad fire detector for the surveillance of air ducts in buildings.

Suitable S-Quad fire detector:

| Part No. | Description |
|----------|----------------|
| S4-715 | Optical Sensor |

The kit is fastened to the outside of the air duct. The Venturi tube is lead into the duct through a hole drilled for this purpose. The air streaming through the air duct is picked up by the Venturi tube and led via the deflecting unit inside the housing directly to the detector for subsequent evaluation.

The inserted S-Quad fire detector is directly connected to the analog loop of the Fire Alarm System. The operation and indication of alarm and fault messages is given at the connected fire alarm panel.

Subpackage

| | |
|-----|--|
| 1 x | Short screw – to fix the Venturi tube in the enclosure |
| 3 x | Long screws – to fix the air duct kits enclosure on the air duct |
| 1x | Rubber gasket (opening of enclosure ↔ Venturi tube) |
| 1x | End cap for venturi tube (inside the air duct) |

2 Mounting

The required mounting position is indicated by the arrow  on the top of the enclosure. The alignment of the air duct kit is correct if the arrow points into the same direction as the air flow inside the duct.

The arrow shaped bottom of the enclosure provides a quick info for the correct positional arrangement of the air duct kit.



- To avoid any damage to the devices, the supplied material in the subpackage must be used for mounting the air duct kit.
- If the minimum dimensions of the entry and exit paths can not be provided, care must be taken to ensure a homogenous air stream at the Venturi tube when installing the air duct detector.
- The direction of the air flow is not comparable with the upstream/downstream distances. This way denotes the close area of the Venturi pipe. Observe the appropriate rated pipe diameter!
- It may be necessary to have the air duct cross-section adapted by the company - installing the air duct - to the local dimensions in order to ensure correct operation of the air duct detector.

Dimensions

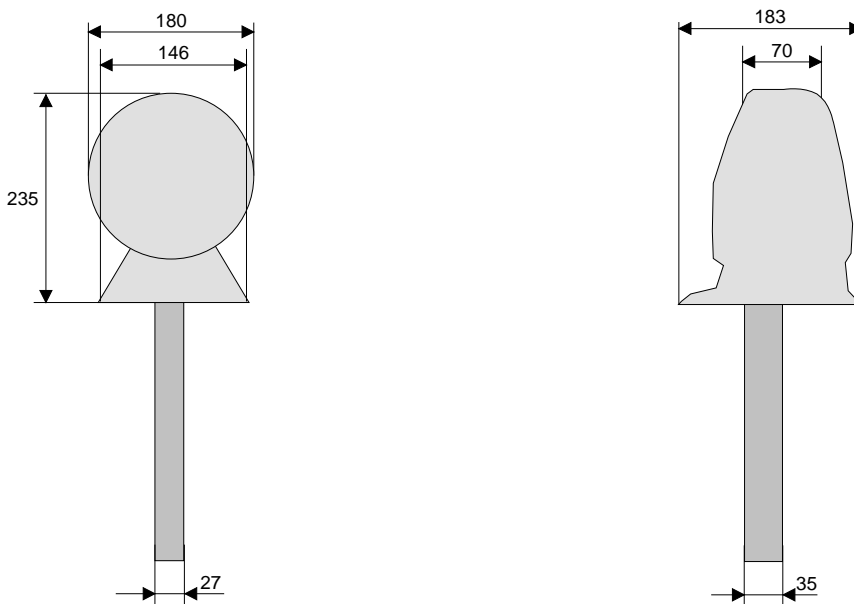

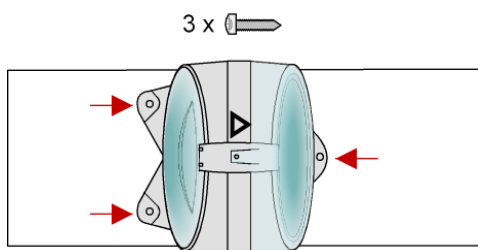

Fig. 1: Dimensions

2.1 Mounting the air duct kit

The required mounting position is indicated by the arrow  on the top of the enclosure. The arrow shaped bottom of the enclosure provides a quick info for the correct positional arrangement of the air duct kit.



Mount the kit with the supplied three long screws on the duct. Only the three marked holes may be used to fasten the kit on the air duct.

The kit can be mounted in different positions (top, side, bottom) on the air duct without affecting the proper operation.

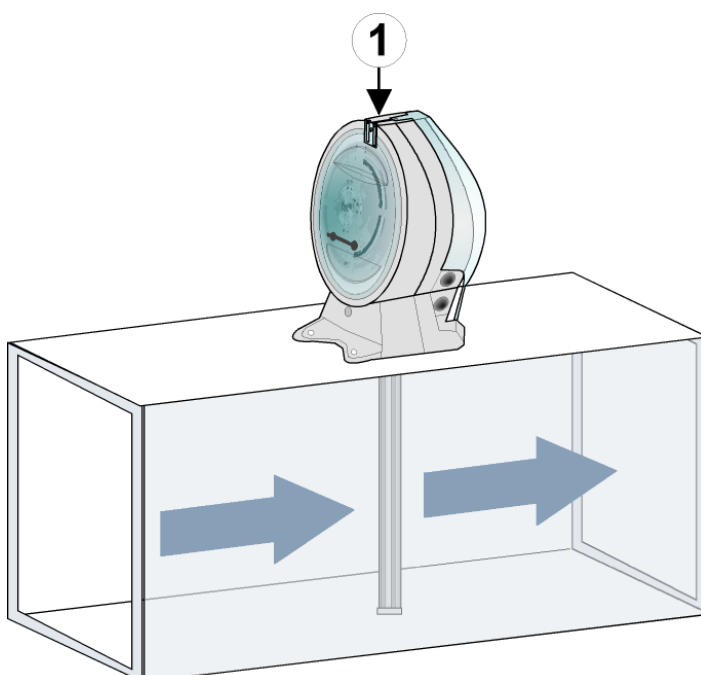

The arrow  on the housing of the air duct kit must point into the direction of the air flow.

The Venturi tube must be aligned in the middle of the ducts diameter and lead into the duct.

Fig. 2: Mounting and orientation of the air duct detector

2.2 Calculation of upstream and downstream distances

Air duct with circular cross-section

Air duct with rectangular cross-section

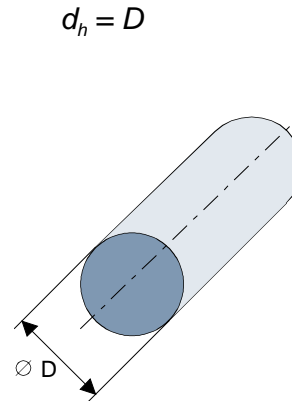
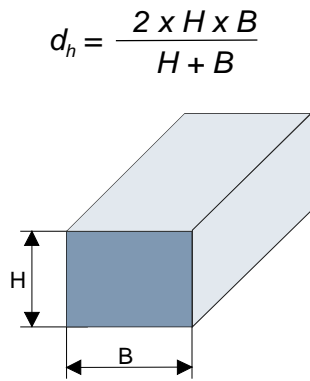

In order to prevent incorrect measurements the air through the duct detector should be in the same direction as the air flow through the duct. For applications with a detector mounting close to reducing dampers and regulating flaps, filter units or bends, the following minimum distances must be observed:

- upstream** ➔ **at least 3 x the nominal diameter of the air duct**
- downstream** ➔ **at least 5 x the nominal diameter of the air duct**

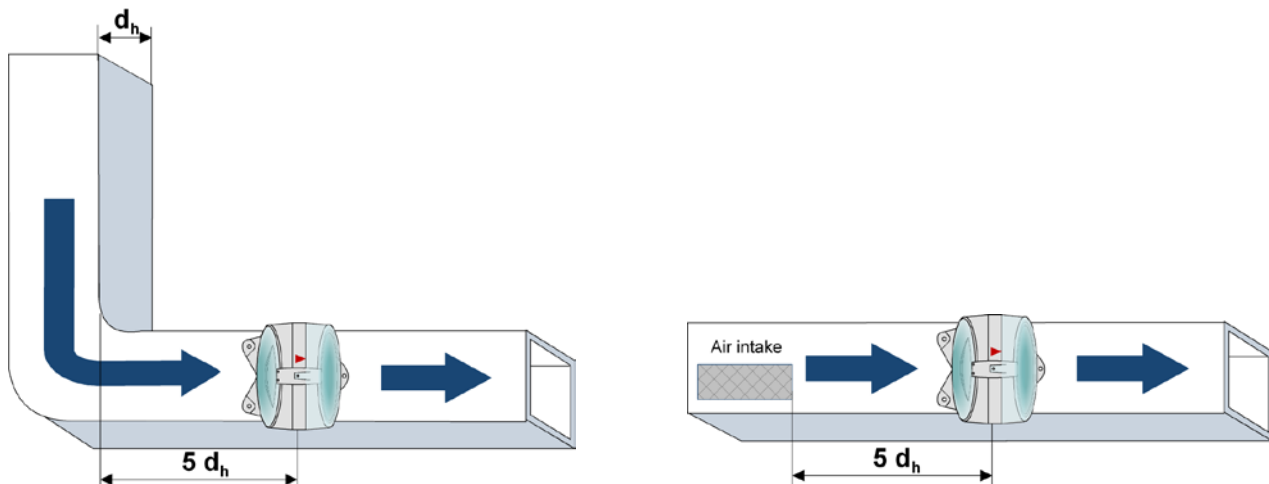

Fig. 3: Air duct detector after a bend in the duct system and downstream from an air intake (Example)

Different application samples for the air duct mounting are shown in following diagrams to calculate the required air inlet/exhaust sections.

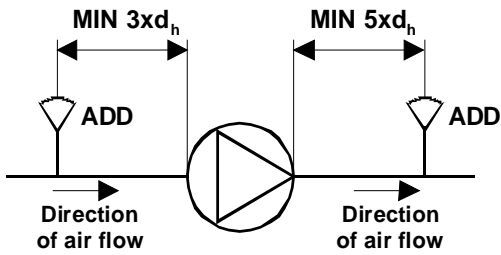

Fig. 4: Exhauster

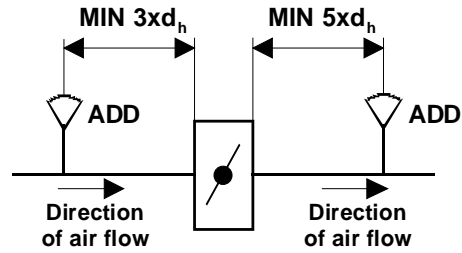

Fig. 5: Reducing damper or regulating flap

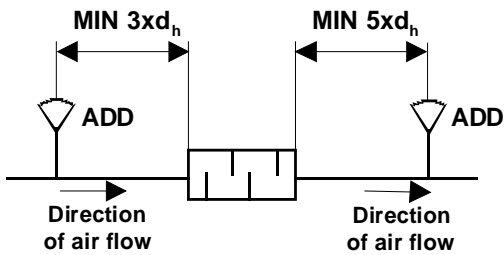

Fig. 6: Silencer

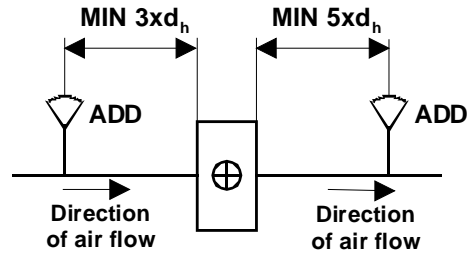

Fig. 7: Air reservoir

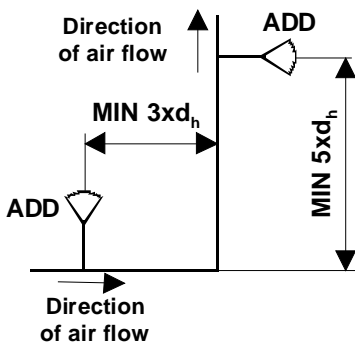

Fig. 8: Bend in the air duct system

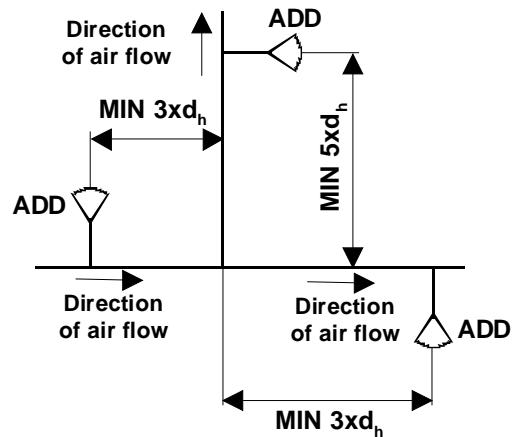

Fig. 9: Branch in the air duct system

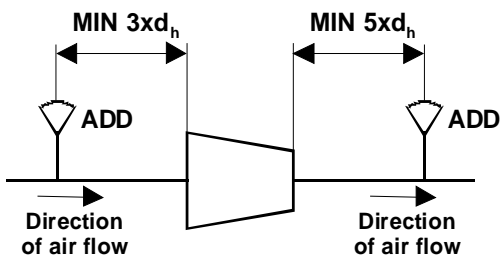

Fig. 10: Diameter decrease or increase in the air duct system

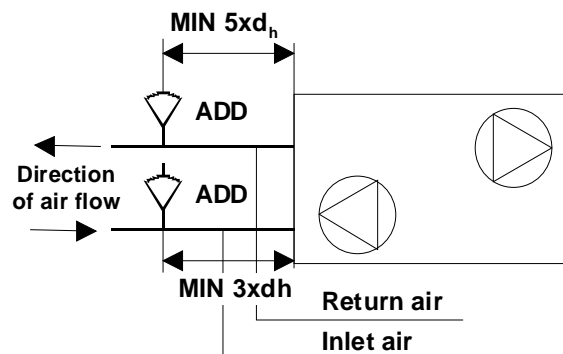

Fig. 11: Air control unit

2.3 Mounting → Venturi tubes up to 600 mm

To mount the air duct (with or without the optional mounting kit Part No. S4-34760-99) with a pipe length of max. 600 mm the air duct must be drilled as shown in the figure.

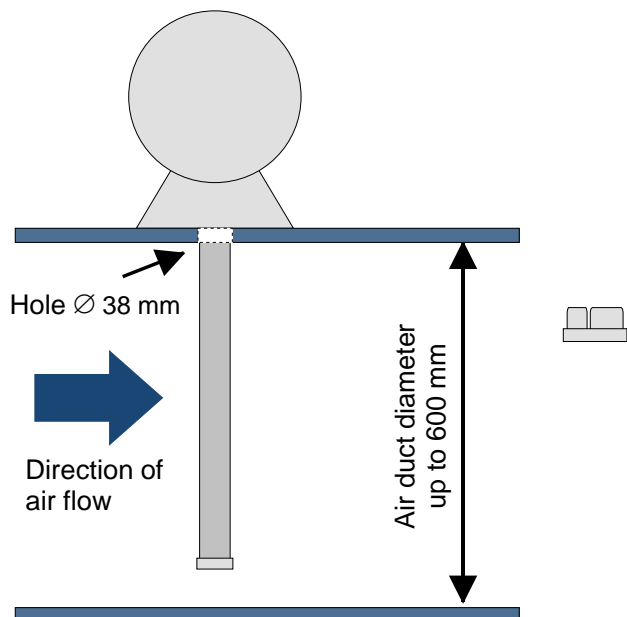

Fig. 12: Venturi tubes up to 600 mm

Mounting information!

Drill a hole (\varnothing 38 mm) in the air duct and deburr the borehole.

Cut the Venturi tube to the required length (refer Section 2.5 "Adapt the Venturi tube length").

Close the end of the Venturi tube by means of the supplied sealing cap.



The immersion depth of the Venturi tube in the air duct should be 90% of the ducts diameter.

Observe distance caused by the optional mounting kit if required!

Refer to section 2.6 "Mounting the Venturi tube"!

2.4 Mounting → Venturi tubes between 600 mm and 2800 mm

To mount the air duct (with or without the optional mounting kit Part No. S4-34760-99) with a pipe length of more than 600 mm the air duct must be drilled at two points as shown in the figure.

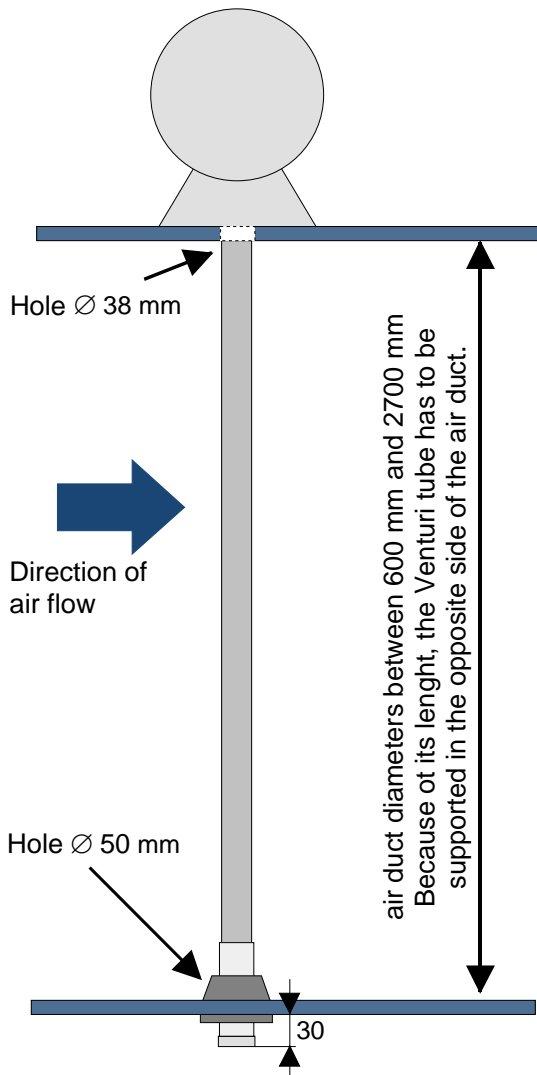

Mounting information!

Drill a hole (\varnothing 38mm) in the air duct and deburr the borehole.

upper hole → \varnothing 38 mm

bottom hole → \varnothing 50 mm

Cut the Venturi tube to the required length (refer Section 2.5 „Adapt the Venturi tube length“).

Seal the borehole of the air duct on the lower end of the Venturi tube with the supplied plastic gasket (use only Part No. S4-34760-15 / S4-760-28).

Insert rubber gasket in the lower borehole of the air duct (\varnothing 50 mm).

Close the end of the Venturi tube by means of the supplied sealing cap.

The Venturi tube should not protrude by more than 30 mm above the air duct.

Fig. 13: Venturi tubes between 600 mm and 2800 mm



The Venturi tube must be about 30 mm longer as the diameter of the air duct.

Observe distance caused by the optional mounting kit if required!

Refer to section 2.6 “Mounting the Venturi tube”!

2.5 Adapt the Venturi tube length

The Venturi tube of the air duct kit has to be adapted to the diameter of the air duct system. Venturi tubes are available in three different lengths which can then be cut - if needed - to the required length.

| Diameter of the air duct | Length of the Venturi tube | Part No. |
|--------------------------|----------------------------|-------------|
| 140 mm to 600 mm | 600 mm | S4-34760-06 |
| 600 mm to 1400 mm | 1500 mm | S4-34760-15 |
| 1400 mm to 2700 mm | 2800 mm | S4-34760-28 |

1) For systems with a tube length of more than 600 mm the Venturi tube must be about 30 mm longer as the diameter of the air duct.

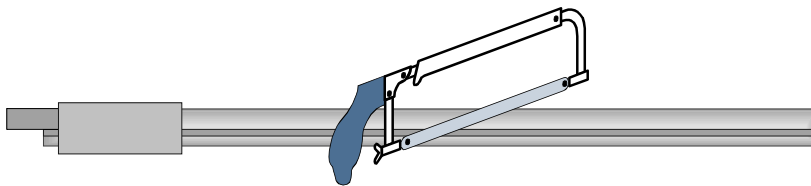
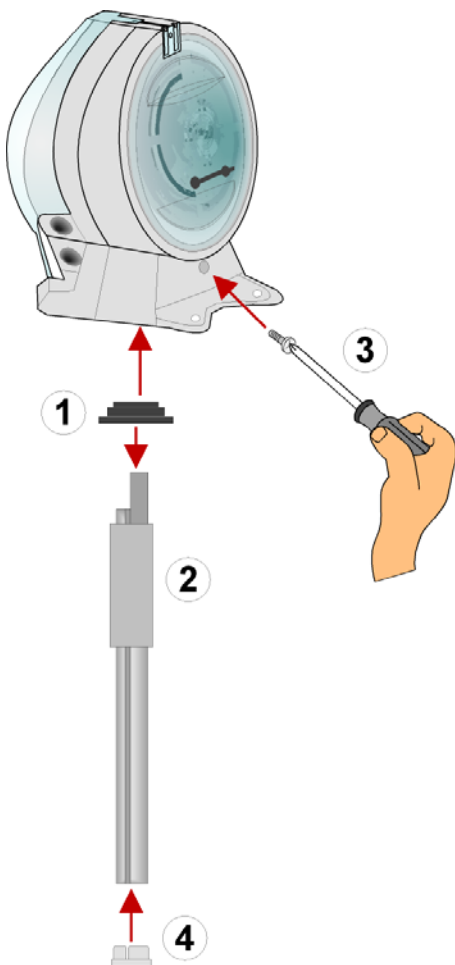

Fig. 14: Cutting the Venturi tube to the required length.

2.6 Mounting the Venturi tube



- Fit the supplied rubber gasket ● on the upper side of the Venturi tube (enclosure ↔ Venturi tube).
- Insert Venturi tube in the correct positional-Rohr arrangement ● into the oval opening of the air duct kit.
- Fasten Venturi tube in the bottom of the enclosure with the supplied short screw ● (subpackage).
- The end of the Venturi tube must be terminated with the supplied end cap ●.

Fig. 15: Mounting the Venturi tube

2.7 Mounting kit for circular and insulated air ducts

The mounting kit (Part No. S4-34760-99) has to be used for mounting on insulated or circular air duct systems. The mounting kit can simply be bent to fit to the shape of the duct. Pre-punched mounting holes are provided for easy installation. Close the openings of the air duct with the supplied rubber grommets (refer to Fig.).

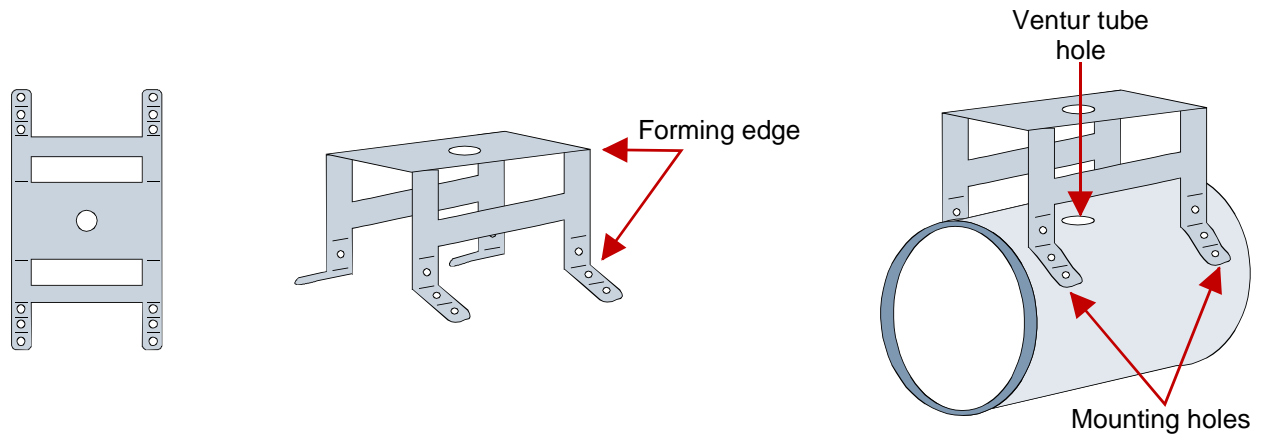

Fig. 16: Mounting kit for insulated and circular air ducts

Mounting example

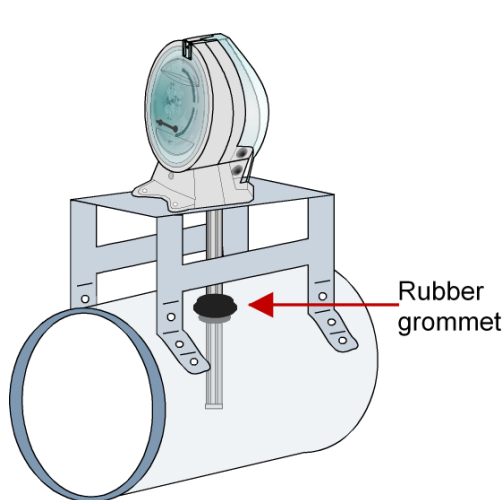

Fig. 17: Circular air ducts

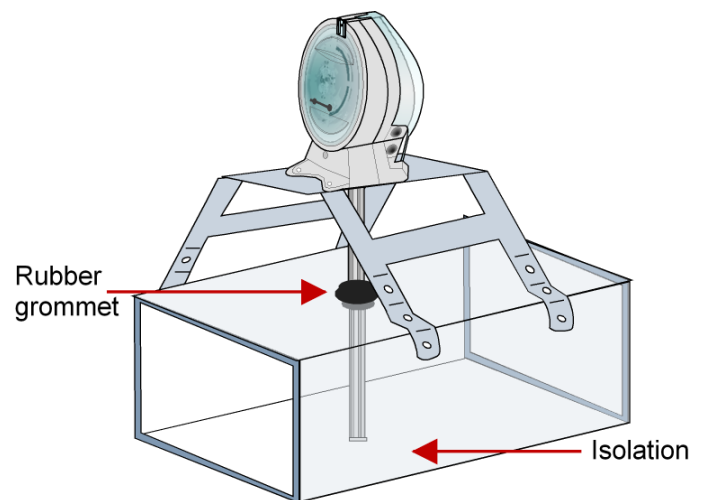



Fig. 18: Insulated rectangular air duct

3 Opening the enclosure

Open enclosure on the detectors side:

1. Lift plastic tab  at the top carefully upwards with a small bladed screwdriver.
2. Unfix transparent cover  by turning it anti clockwise and remove it.

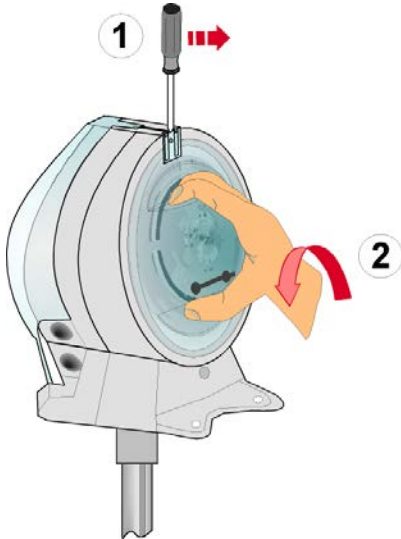

Fig. 19: Open enclosure (Detector side)

Open enclosure on the terminals side:



1. Lift plastic tab  at the top carefully upwards with a small bladed screwdriver.
2. Unfix transparent cover  and remove it .



Fig. 20: Open enclosure (terminal side)

3.1 Detector base wiring

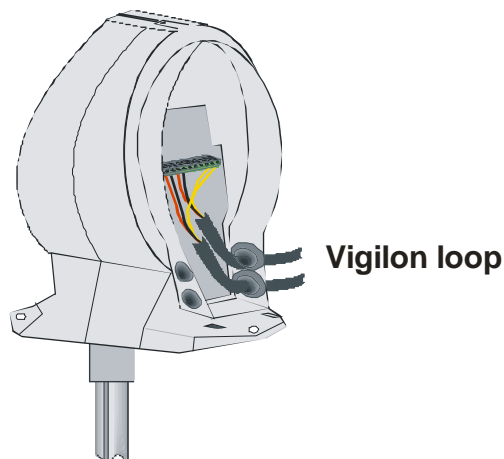

Fig. 21: Cable for loop wiring



The terminal assignment as well as the connection to the Fire alarm panel is detailed in the section 8 "Wiring".

3.2 Install fire detector

The S-Quad (Part No. S4-715) must be aligned to the detector base and mounted by turning the detector clockwise into the base until it engages.

The S-Quad is connected and powered via the loop of the Fire alarm control panel.

Alarm and fault messages are transmitted via the loop to the connected Fire alarm control panel and indicated on the panel display.

An activated alarm is also local indicated with the flashing red detector LED . The LED is visible for the mounted detectors in the air duct kit through the transparent cover.



Fig. 22: Insert S-Quad sensor

- An external remote indicator may be connected if required.
- It is recommended to use the removal tool to insert/remove the detector from the base.
- Fix flow indicator (supplied Film strip) inside the cover (refer to Fig. 25).
- Replace cover in correct positional arrangement.

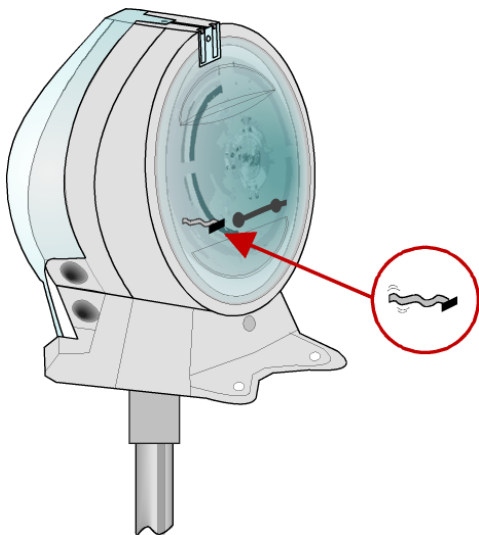

Fig. 23: Flow indicator (Film strip)

4 Final check

- The air duct kit must be fastened correctly on the air duct by using the supplied three screws (or optional mounting kit).
- The ambient conditions must match the specifications of the components.
- The arrow head on the air duct kit must point into the direction of the air flow inside the air duct.
- The rubber gasket between the Venturi tube and kit is fitted as required and the tube is fastened with the appropriate screw in the air duct kit.
- The lower end of the Venturi tube is terminated with the supplied end cap.
- The cabinet must not show any signs of damage. Additional vents into the cabinet are not permitted.
- If the air flow against the Venturi tube is present the flow indicator oscillates. The oscillating speed depends on the air flow speed inside the air duct.
- The detector base is correctly wired and all terminal screws are tighten.
- The cover is properly engaged at the fixing points to ensure the IP protection rating.

5 Maintenance

If the air duct kit or the Vigilon panel is undergoing service and maintenance work observe ensure appropriate action is taken to prevent unwanted alarms.

To test the air duct detector enabled the test operation mode for this detector zone at the panel.

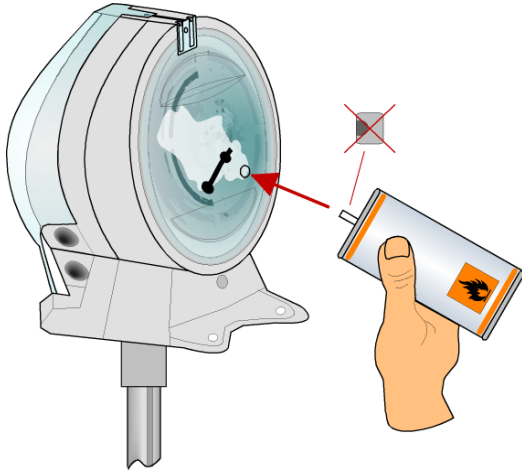

1. Pull the seal of the service opening carefully outwards and turn it aside.
2. Remove spraying nozzle from test gas can.
3. Press the valve of the test gas can towards the inspection hole.
4. Apply test gas in the inside of the chamber by briefly pressing the test gas can
5. Wait for alarm activation of the detector (red LED flashes, as the case indication at the panel).
6. If the detector is not activated apply again some test gas in frequent intervals.
7. Close opening with the seal after testing.

Fig. 24: Test alarm activation of the detector



Detector zones which are in test mode will not cause a test fire condition!

6 Specifications

Air duct detector housing (Part No. S4-34760)

| | |
|------------------------|---|
| Terminals | : 1.5 mm ² max. |
| Air velocity | : 1 m/s to 20 m/s |
| Ambient temperature | : -10 °C to +60 °C |
| Storage temperature | : -15 °C to +65 °C |
| Protection class | : IP 54 |
| Housing | : ABS plastic |
| Colour | : grey (with transparent cover) |
| Weight | : approx. 800g (without detector / detector base) |
| Dimensions (W x H x D) | : 180 x 235 x 183 (mm) |

S-Quad (Part No. S4-715)

| | |
|-----------------------------|--|
| Operating voltage | : 35 V to 41 V |
| Alarm indicator | : red LED, flashing |
| Air velocity range | : 0 to 5.000 ft/min. ft/min. |
| Ambient temperature | : -20 °C to +50 °C |
| Temperature, storage | : -25 °C to +70 °C |
| Ambient humidity | : □ 95% relative humidity (non-condensing) |
| IP rating | : IP 43 (with base + option) |
| Housing | : ABS plastic |
| Colour | : white (similar to RAL 9010) |
| Weight | : approx. 110 g |
| Dimensions (with base) | : Ø 117 mm, H = 62 mm |
| Detector specification | : EN 54-7, CEA 4021 |
| EN 54-17 (section 4.8) data | : V _{max} 42V V _{nom} 40V V _{min} 24V V _{SO} max 16V V _{SO} min 8V IC max 0.4A IS max 1A IL max 20uA ZC max 0.1ohms |

Venturi tube

| Part No. | S4-34760-06 | S4-34760-15 | S4-34760-28 |
|-------------|-------------|-------------|-------------|
| Length (mm) | 600 | 1500 | 2800 |
| Weight (Kg) | 0,2 | 0,6 | 1,2 |
| Material | aluminium | | |

7 Accessories

| Description | Part No. |
|---|-------------|
| Air duct kit | S4-34760 |
| Venturi tube 600 mm | S4-34760-06 |
| Venturi tube 1500 mm | S4-34760-15 |
| Venturi tube 2800 mm | S4-34760-28 |
| Mounting kit for circular and insulated air ducts | S4-34760-99 |
| S-Quad Optical Sensor | S4-715 |

8 Loop Wiring

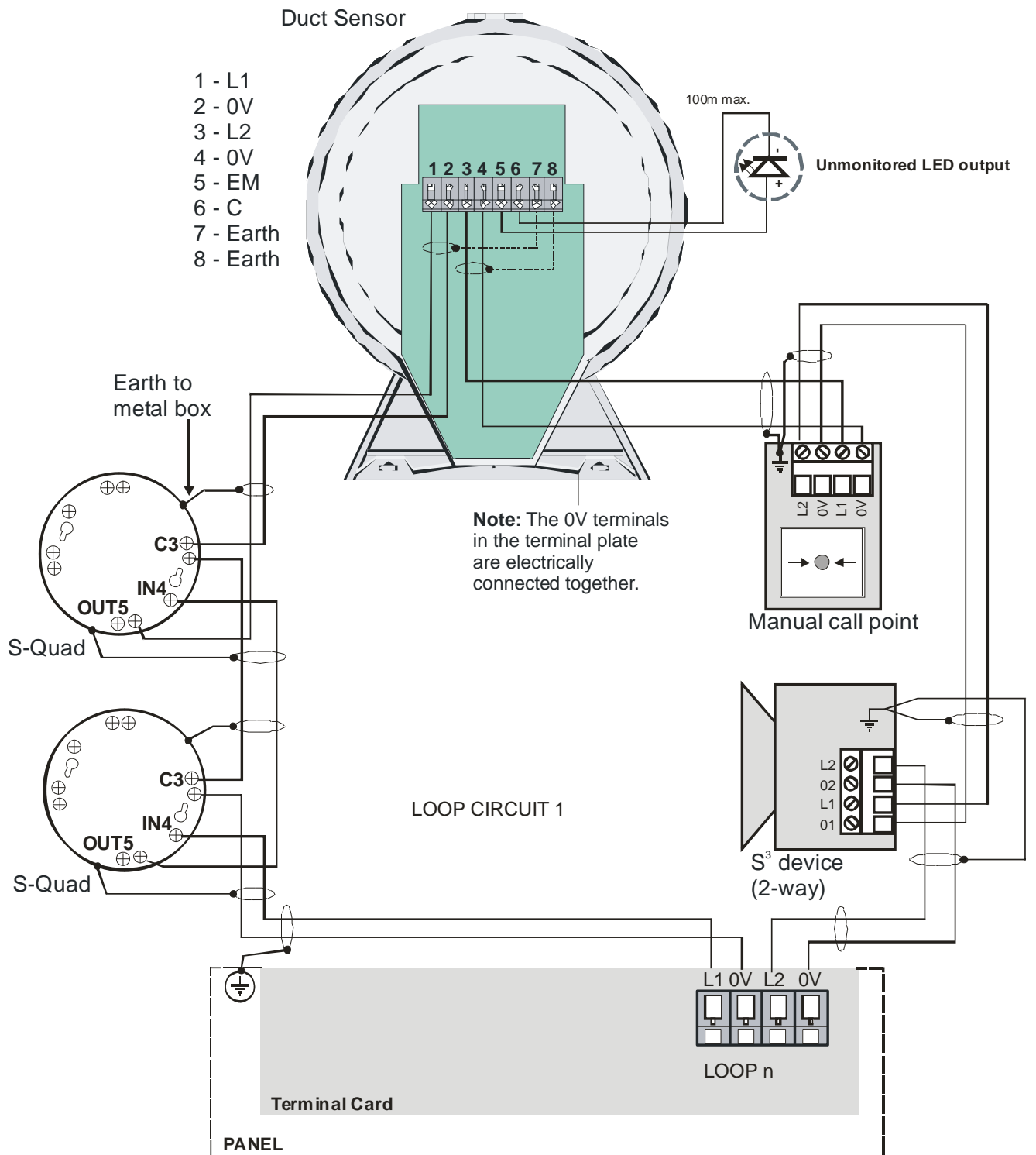
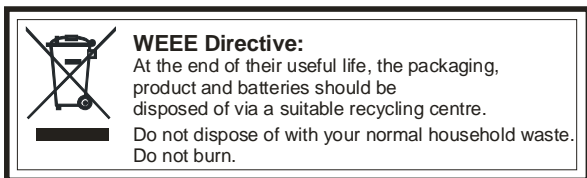
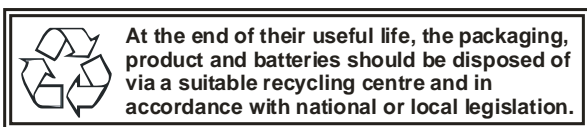

Fig. 25: Loop Wiring



Fig. 26: Vigilon loop wiring

Page intentionally left blank.



Honeywell Gent reserves the right to revise this publication from time to time and make changes to the content hereof without obligation to notify any person of such revisions of changes.



Honeywell Gent
140 Waterside Road, Hamilton Industrial Park, Leicester LE5 1TN
Tel : 0116 2462 000